

# LED PILOT LIGHTS

## Guarded LED Pilot Lights for Group B Applications

**Class I, Groups B, C & D**  
**Class II, Groups E, F & G**  
**NEMA 3, 4, 7 & 9**

### STANDARD FEATURES

- Suitable for panel or surface mount applications. All candelabra base LED lights can be relamped from the front by removal of the lens cap.
- Made with 3/4" NPSM threads.
- All LED pilot lights have 8" flexible leads, other lengths on special order, or screw terminal.
- Add suffix T to P/N for screw terminal.
- All lens caps are black anodized aluminum finish with colored glass lens.
- Maximum installation thickness: 1-13/16" on Long Barrel (Long Series), 5/8" on Short Barrel (Short Series).

#### LED Advantages:

- 10 Year/100,000 hour service life under normal ambient conditions.
- Up to 4x more energy efficient.
- Improved resistance to shock and vibration.
- LEDs operate significantly cooler than traditional lamps.
- Ultra bright cluster LED's.

STANDARD SERIES			
Long Barrel Cat #	Short Barrel Cat #	Description	Weight (lbs.)
XLRL-GH	XLSRL-GH	Red	1/2
XLAL-GH	XLSAL-GH	Amber	1/2
XLGL-GH	XLSGL-GH	Green	1/2
XLWL-GH	XLSWL-GH	White	1/2
XLBL-GH	XLSBL-GH	Blue	1/2

\*Add suffix T to P/N for screw terminal (Example: XLRLT-GH)

120V dual polarity supplied as standard. 5,12,24,48,60 volts optional, consult factory.

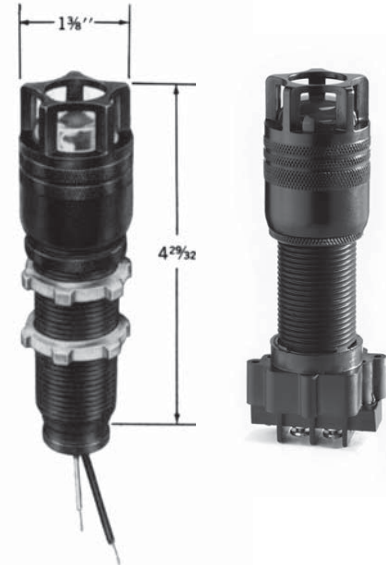

**XL Long Series (Panel Mount)**



**XLS Short Series (Surface Mount)**