

XDHLFCX

REV	REVISION	BY	ECN	DATE

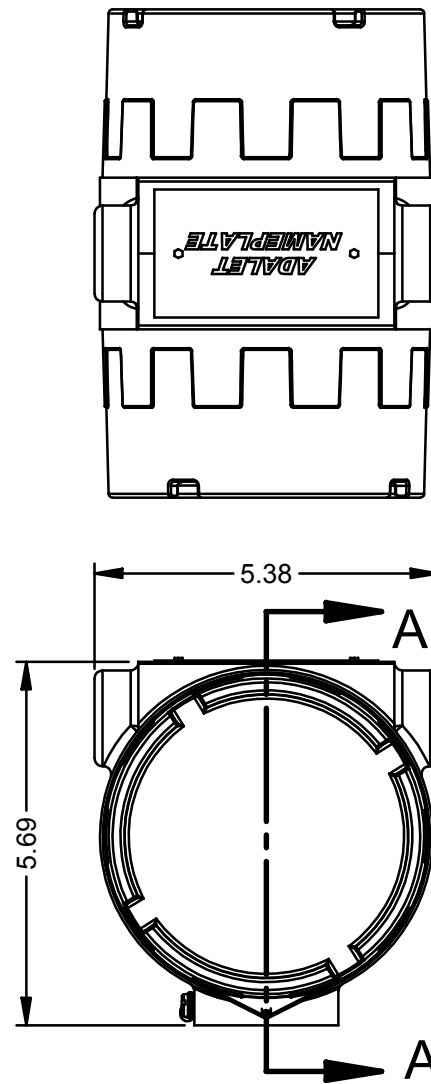

- POWER SIDE COVER OPTIONS:
1. FLAT SOLID - STANDARD
 2. DOME GLASS - ADD SUFFIX "A"
 3. FLAT GLASS - ADD SUFFIX "B"
 4. DOME SOLID - ADD SUFFIX "C"

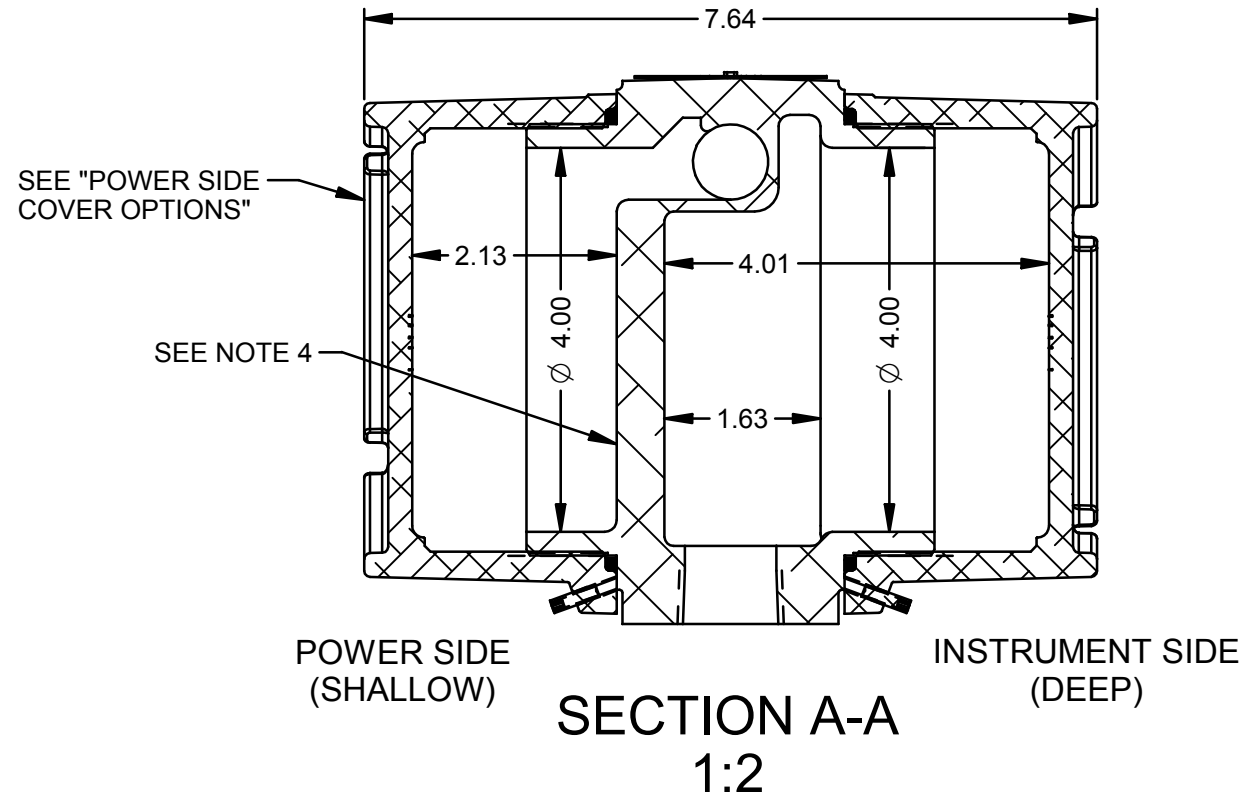
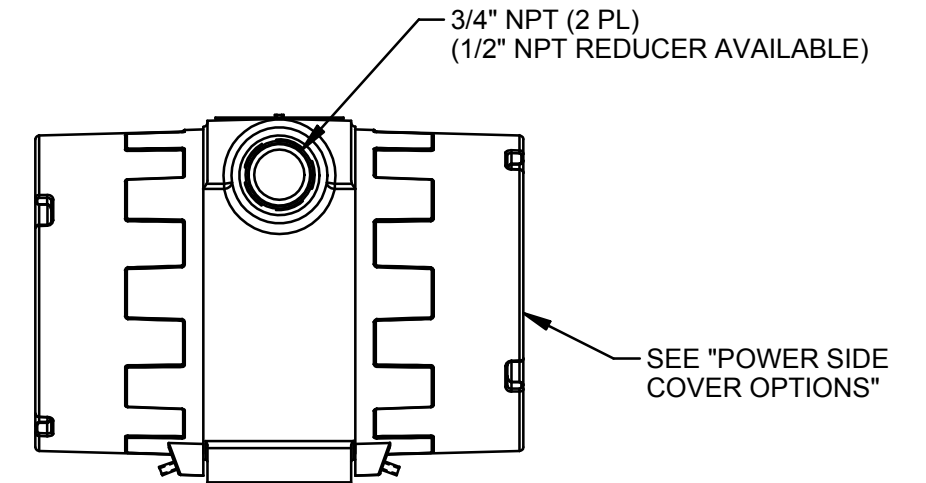

NOTES:

1. STANDARD APPROVALS: UL/cUL CLASS I, DIVISION 1, GROUP B; NEMA TYPES 4X/7/9. ATEX APPROVAL OPTIONAL - - CONSULT FACTORY
2. STANDARD FINISH: SAFETY BLUE POLYESTER POWDERCOAT. OTHER COLORS AVAILABLE
3. TWO (2) TO TWELVE (12) POINT, POWER SIDE TERMINAL STRIP WITH SEALED PASS-THROUGH AVAILABLE. (ADD SUFFIX "2T", "4T", "6T", "8T", "10T", OR "12T")
4. OPTIONAL INTERNAL WALL MODIFICATIONS AVAILABLE (DRILL & TAP, REMOVE MATERIAL) - - CONSULT FACTORY
5. OPTIONAL FRONT BOSS ENTRY AVAILABLE. (SEE "ENTRY OPTIONS" LIST FOR SIZES)
6. FOUR (4) OPTIONAL 1/4-20 HOLES IN FRONT BOSS FOR BRACKET MOUNTING - - CONSULT FACTORY
7. CONSULT FACTORY FOR ADDITIONAL CUSTOM MACHINING

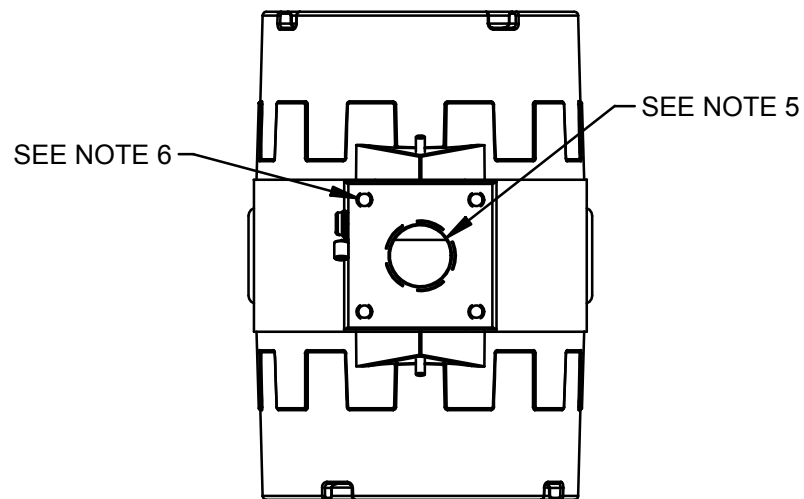

DIMENSIONS SHOWN ARE FOR REFERENCE ONLY, NOT FOR MANUFACTURING. CONTACT ADALET ENGINEERING FOR TIGHT FITS OR TOLERANCE ISSUES!

ENTRY OPTIONS:

1. 1/2" NPT
2. 1/2" NPSM
3. 3/4" NPT
4. 3/4" NPSM
5. 1" NPT
6. 1" NPSM
7. 20mm x 1.5
8. 25mm x 1.5
9. 30mm x 1.5

DO NOT REVISE THIS DWG. IN AUTOCAD 3D GENERATED IN SOLID EDGE

DO NOT SCALE DRAWING UNLESS OTHERWISE SPECIFIED DIMENSIONS ARE IN INCHES. CAST TOLERANCES ON DIMENSIONS NOT OTHERWISE SPECIFIED: ✓ = 1/8" STOCK MIN FILLET OR CORNER RADII 1/8" DRAFT 1 1/2° FRAC ±1/16" ANGLES ± 1°	MACHINE TOLERANCES ON DIMENSIONS NOT OTHERWISE SPECIFIED: ✓ 125 .XX ± .03" .XXX ± .010" FILLET RADII .03" EDGE BREAK .005"-.015" R. or 45° ANGLES ± 0°-30° GAGING FOR THREADED HOLES NOT OTHERWISE SPECIFIED: NPT E-21-2.6 NPSM E-24-1.0	 A SCOTT FETZER COMPANY Enclosure Systems • Cable Accessories Cleveland, OH 44135		TITLE <h2 style="margin: 0;">XDHLFCX</h2> <h3 style="margin: 0;">OUTLINE DRAWING</h3>		DRAWN BY MCP	DATE 1/08/09
		NOTICE TO PERSONS RECEIVING THIS DRAWING: ADALET CLAIMS PROPRIETARY RIGHTS IN THE MATERIAL DISCLOSED HEREON. THIS DRAWING IS ISSUED IN CONFIDENCE FOR ENGINEERING INFORMATION ONLY AND MAY NOT BE REPRODUCED OR USED TO MANUFACTURE ANYTHING SHOWN HEREON WITHOUT DIRECT WRITTEN PERMISSION FROM ADALET TO THE USER.		MATERIAL E-STD-E4	FINISH TUMBLAST	ENG APPROVAL	PLOT SCALE 1=3
				DWG NO <h1 style="margin: 0;">XDHLFCX</h1>		SHT 10F1	REV A