

REV	REVISION	BY	ECN	DATE

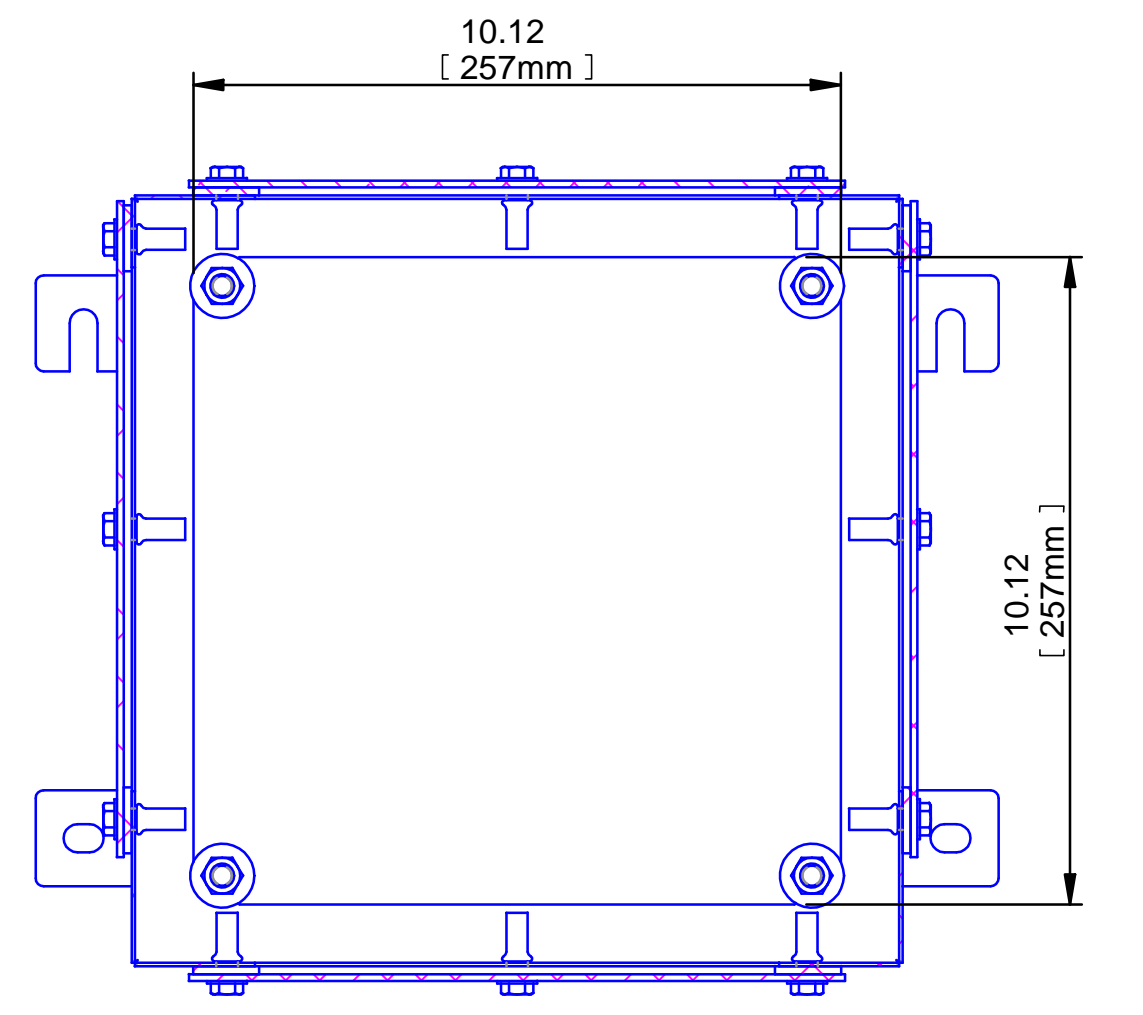

SECTION A-A

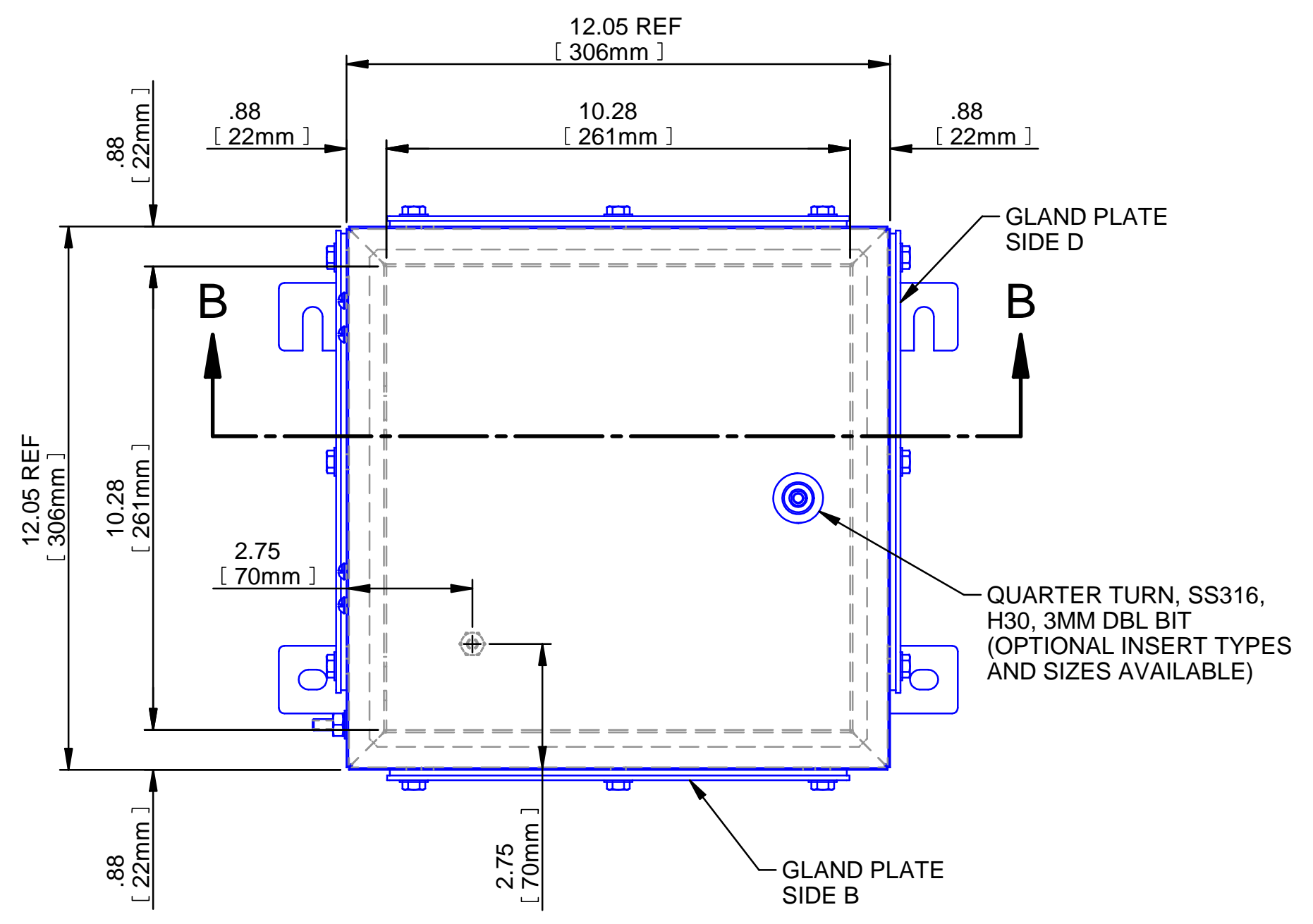
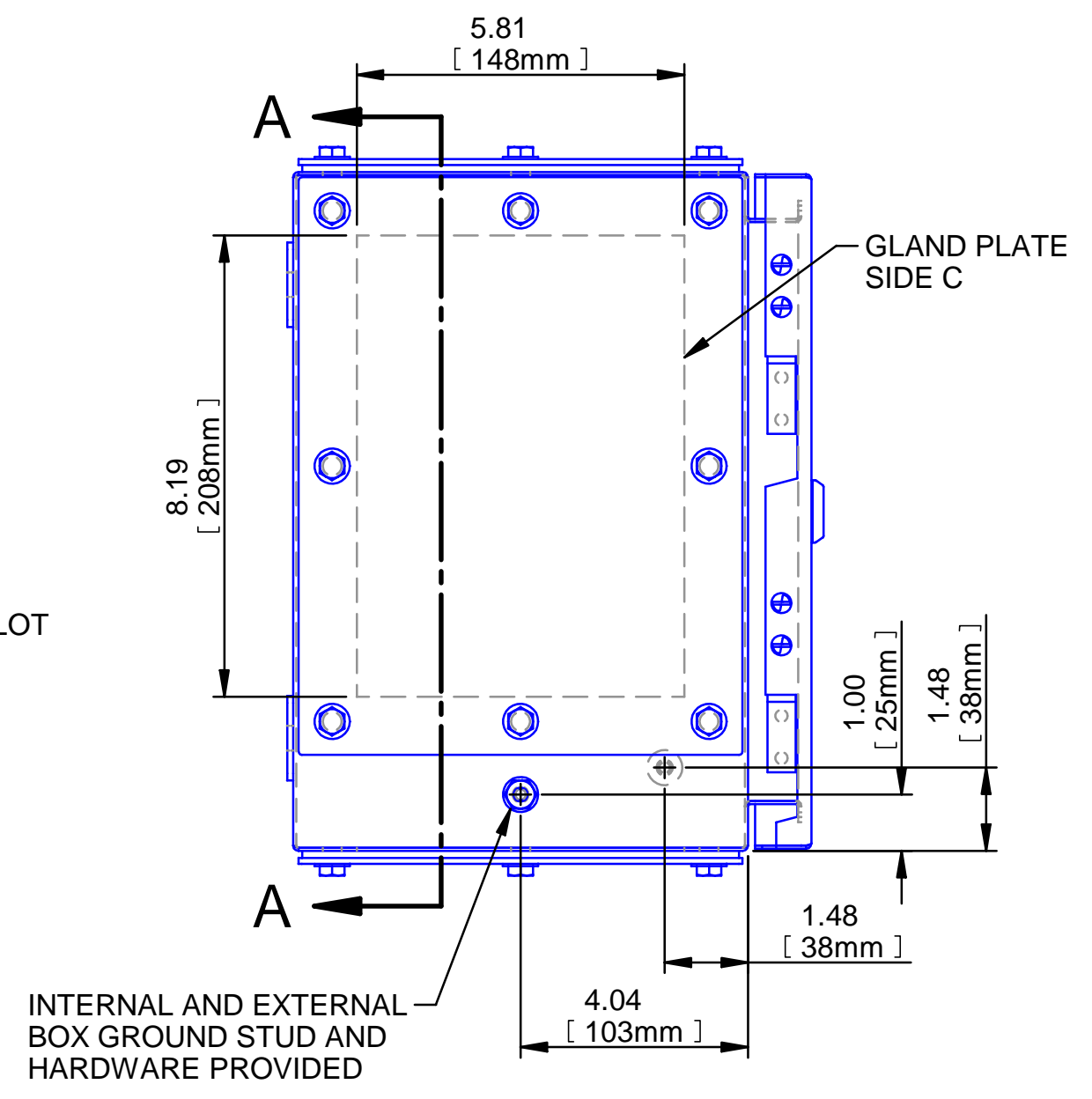
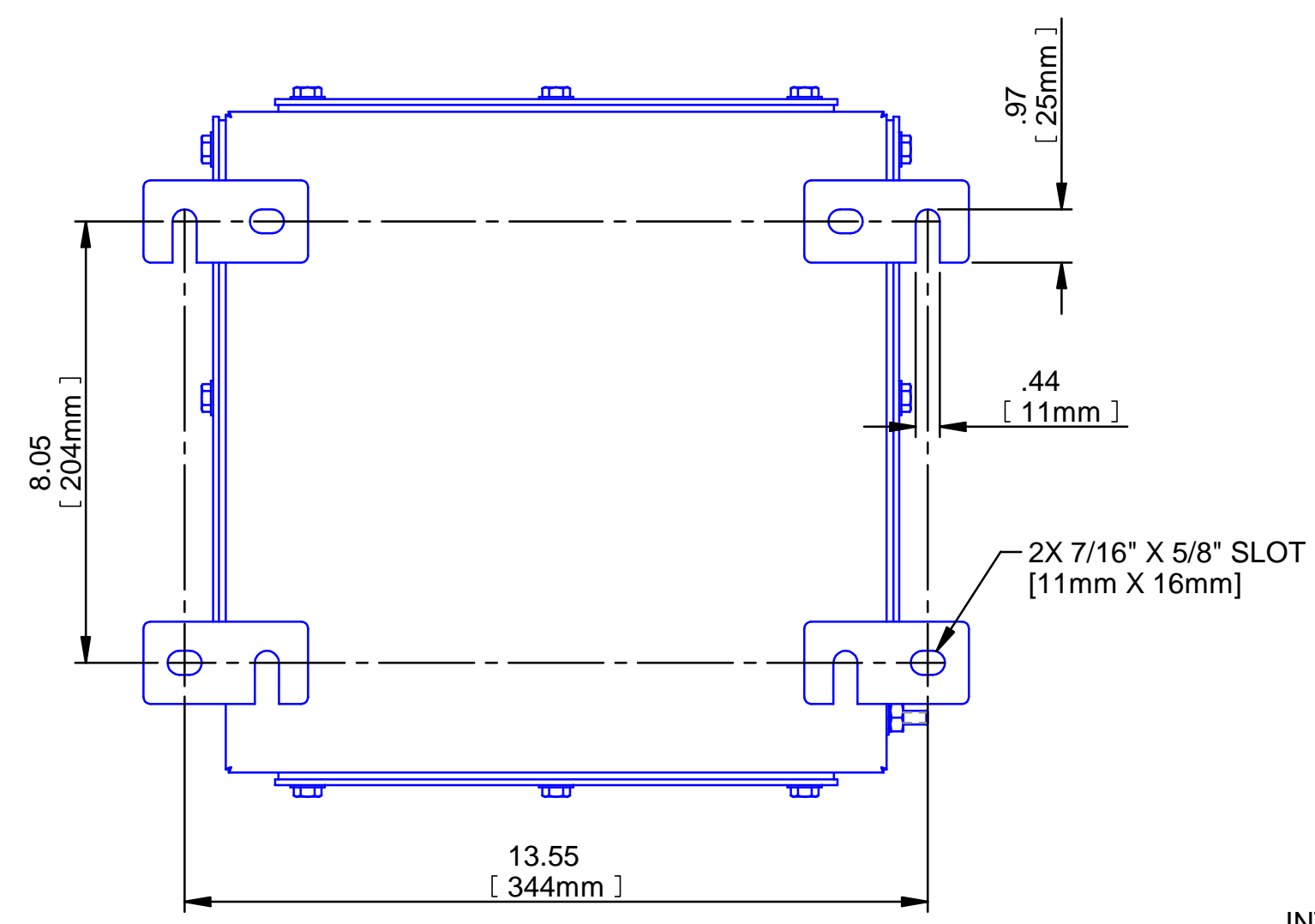
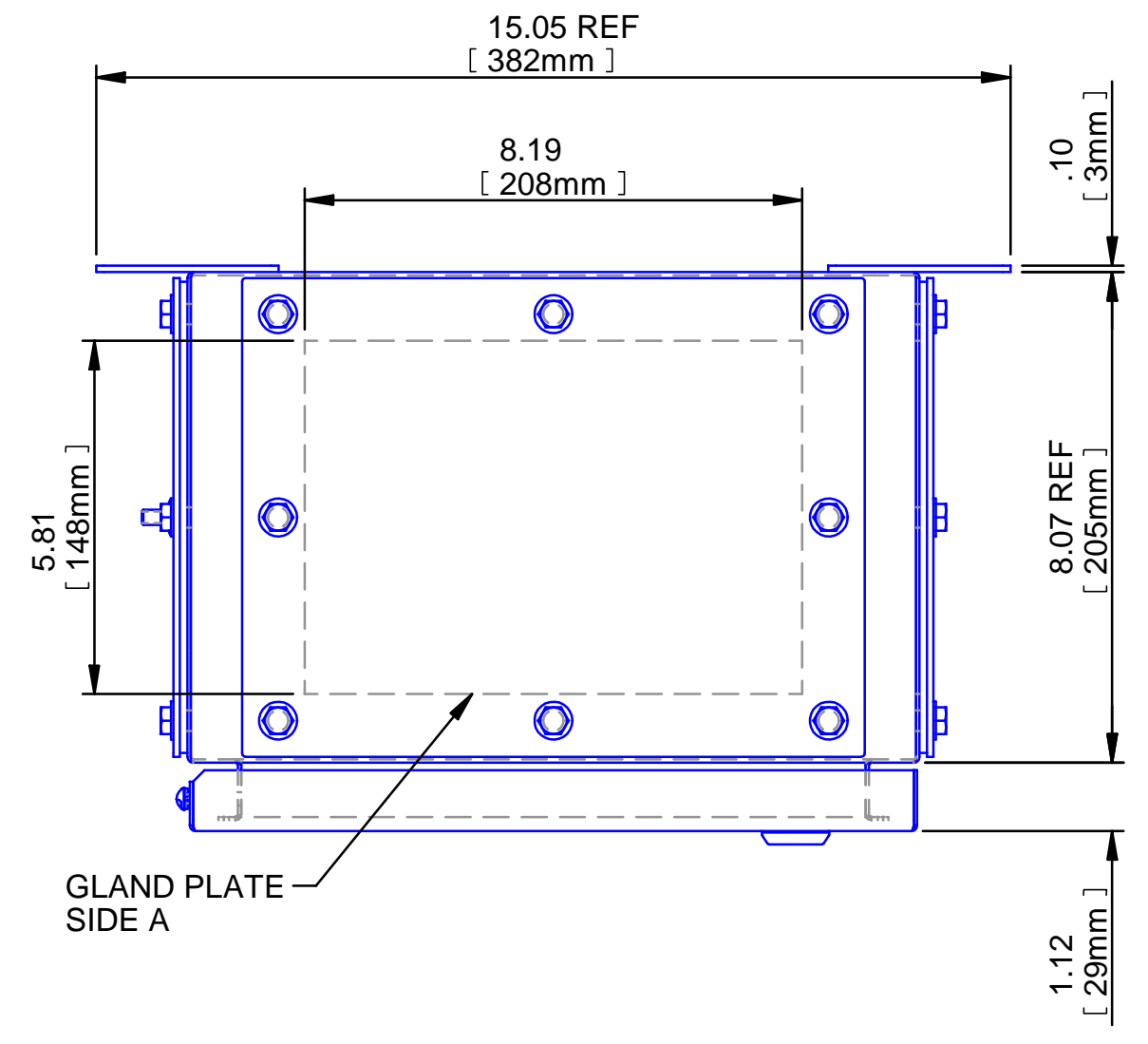
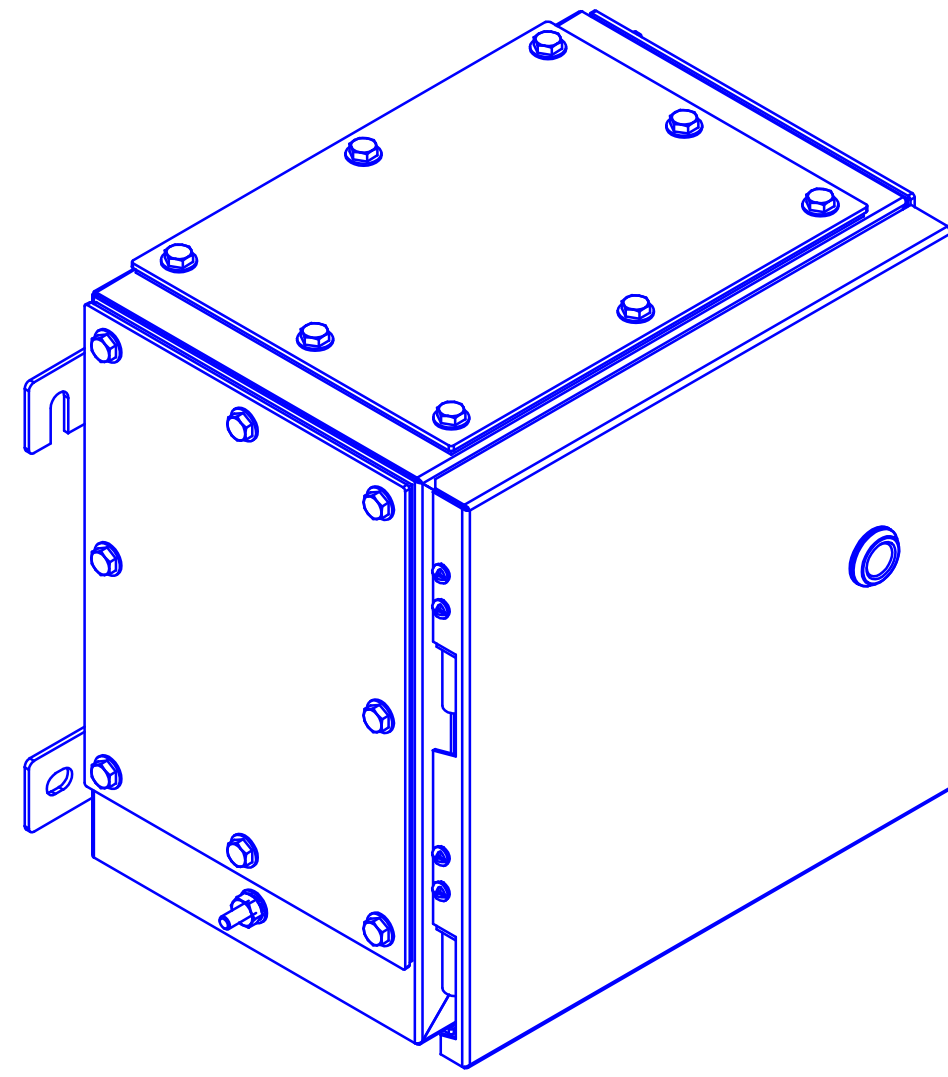
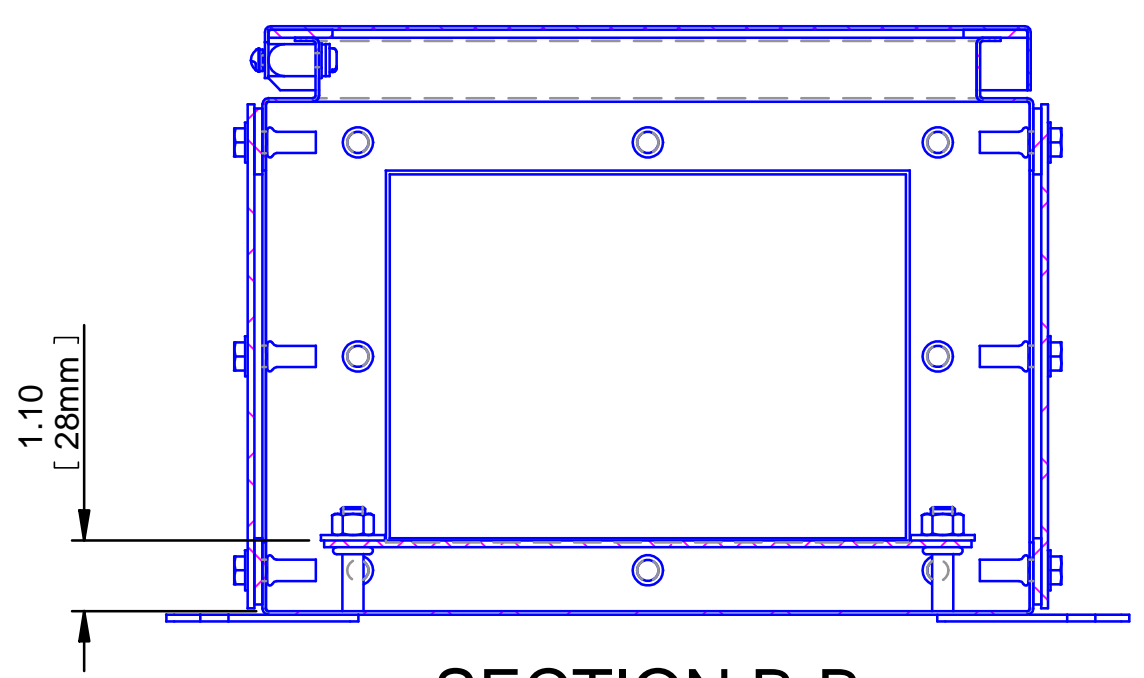

SECTION B-B

UNCONTROLLED DRAWING  
(DATA SUBJECT TO CHANGE  
WITHOUT NOTICE)

**DO NOT REVISE THIS DWG. IN AUTOCAD  
3D GENERATED IN SOLID EDGE**

<p>DO NOT SCALE DRAWING UNLESS OTHERWISE SPECIFIED DIMENSIONS ARE IN INCHES</p> <p>CAST TOLERANCES ON DIMENSIONS NOT OTHERWISE SPECIFIED: 1/2" 1/8" STOCK FILLET OR CORNER RADI 1/8" DRAFT 1:12 PRAC ±1/16" ANGLES ± 1°</p> <p>MACHINE TOLERANCES ON DIMEN- SIONS NOT OTHERWISE SPECIFIED: √ = 125 MIN XX ± .03 XXX ± .010" FILLET RADI .03" EDGE BREAK .035"-.015" R. or 45° ANGLES ± 0°30'</p> <p>GAGING FOR THREADED HOLES NOT OTHERWISE SPECIFIED: MPT E-212.6 NPSM E-241.0</p>		<p><b>ADALET</b> A SCOTT FETZER COMPANY Enclosure Systems • Cable Accessories Cleveland, OH 44135</p> <p>NOTICE TO PERSONS RECEIVING THIS DRAWING: ADALET-PLM CLAIMS PROPRIETARY RIGHTS IN THE MATERIAL DISCLOSED HEREIN. THIS DRAWING IS ISSUED IN CONFIDENCE FOR ENGINEERING INFORMATION ONLY AND MAY NOT BE REPRODUCED OR USED TO MANUFACTURE ANYTHING SHOWN HEREON, WITHOUT DIRECT WRITTEN PERMISSION FROM ADALET-PLM TO THE USER.</p>		<p>TITLE VH-303020 INCREASED SAFETY ENCLOSURE CUSTOMER OUTLINE DRAWING</p>	
<p>DRAWN BY DMS</p>		<p>DATE 12/4/2008</p>			
<p>ENG APPROVAL</p>		<p>PLOT SCALE 1=3</p>			
<p>MATERIAL</p>		<p>DWG SIZE D</p>			
<p>FINISH</p>		<p>DWG NO</p>			
<p>CAT NO</p>		<p>SHT</p>			
<p> </p>		<p>REV</p>			