

UNCONTROLLED DRAWING

(DATA SUBJECT TO CHANGE WITHOUT NOTICE)
FOR ADDITIONAL HELP CONTACT ENGINEERING@ADALET.com

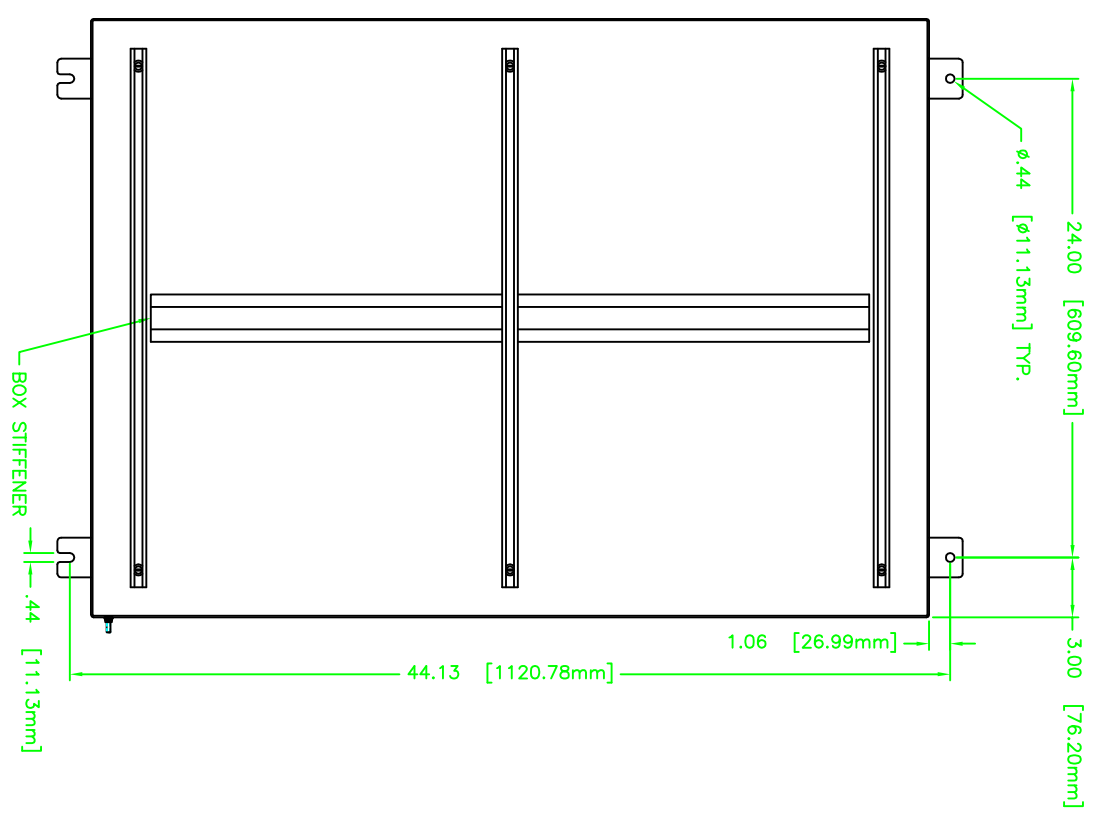
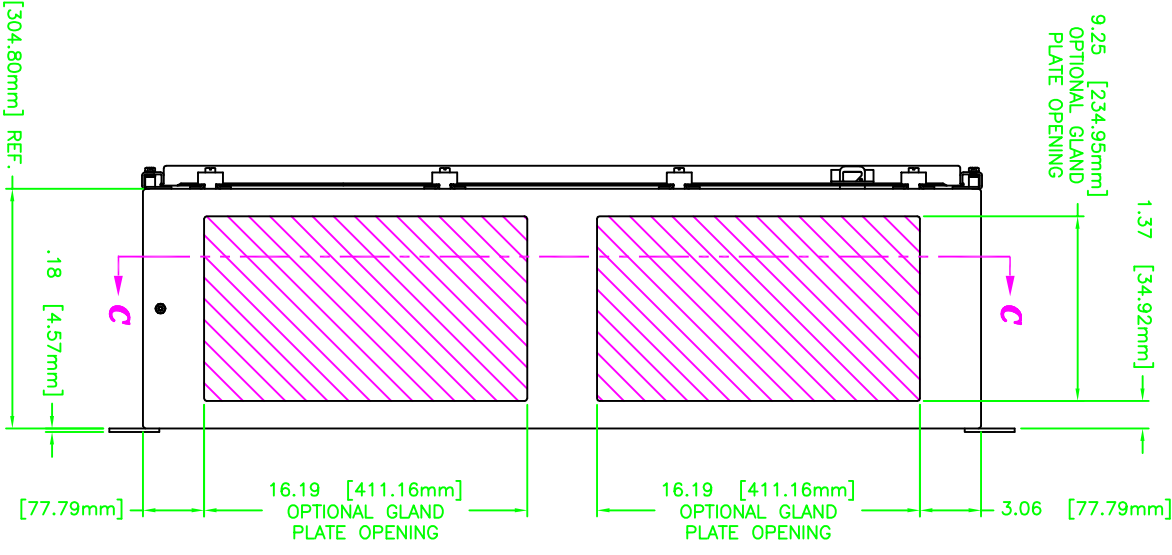
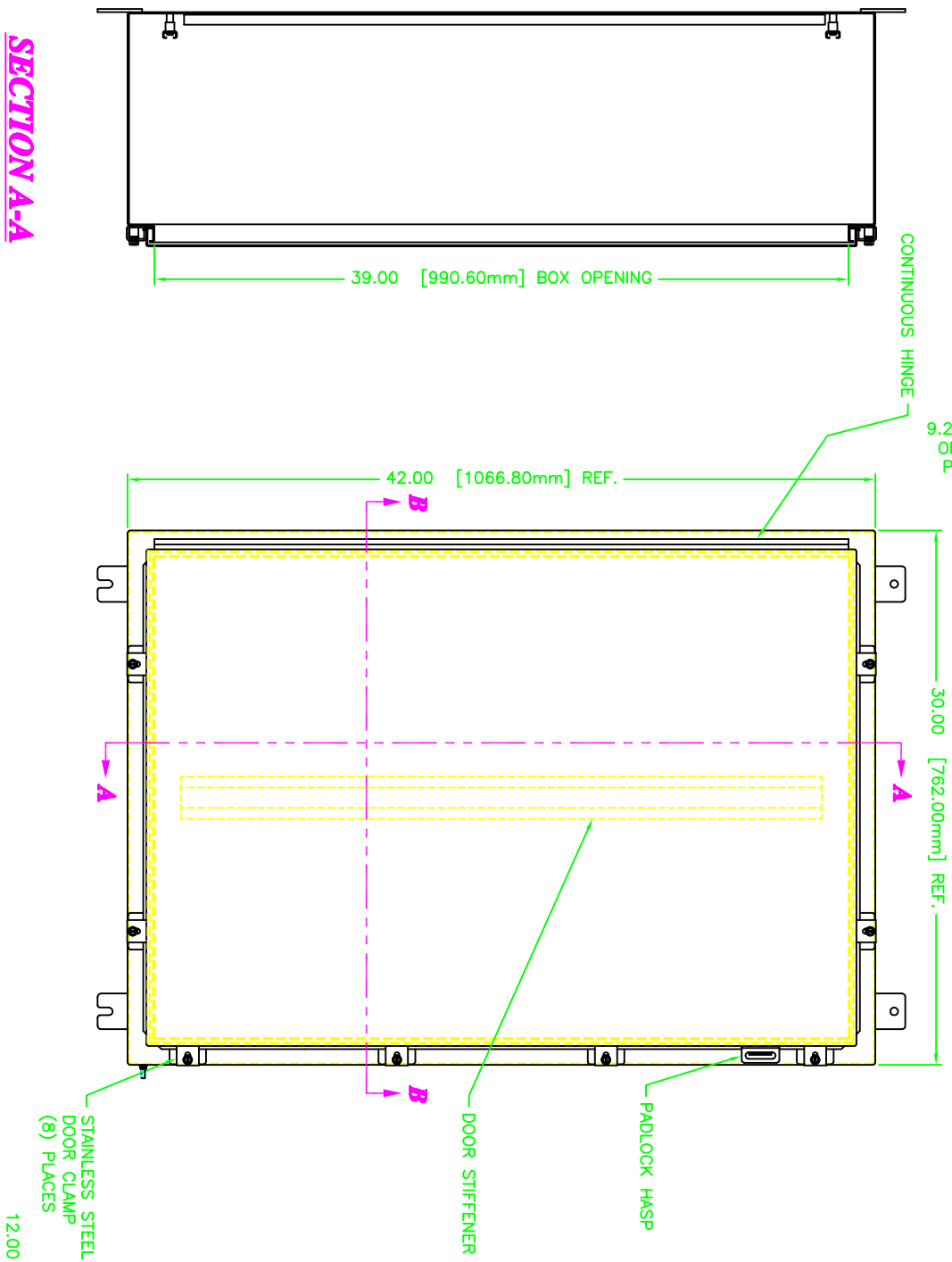
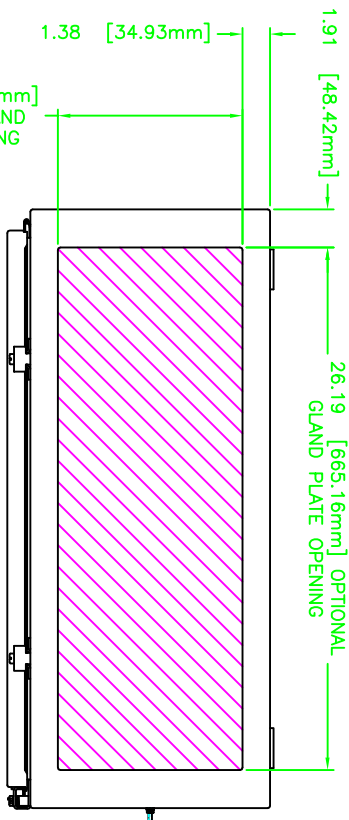

SECTION C-C

ENCLOSURE MATERIAL	CATALOG NUMBER	PART NUMBER
SS316L	TN4X6-423012U	M11411
SS304	TN4X-423012U	N/A

ADALET
 BUILDING AUTOMATION SPECIALISTS
 1700 W. 14th Street, Suite 100
 Phoenix, AZ 85007
 (602) 997-8888
 www.adalet.com

ADALET
 A SCOTT FITZGER COMPANY
 1700 W. 14th Street, Suite 100
 Phoenix, AZ 85007
 (602) 997-8888
 www.adalet.com

DATE	12/23/08
BY	CLB
SCALE	1=5
DRAWING NO.	423012
REV.	10F1 A