

REV	REVISION	BY	ECN	DATE
A	INITIAL RELEASE	CLB	ECN	12/23/08

423008

UNCONTROLLED DRAWING

(DATA SUBJECT TO CHANGE WITHOUT NOTICE)
 FOR ADDITIONAL HELP CONTACT ENGINEERING@ADALET.com

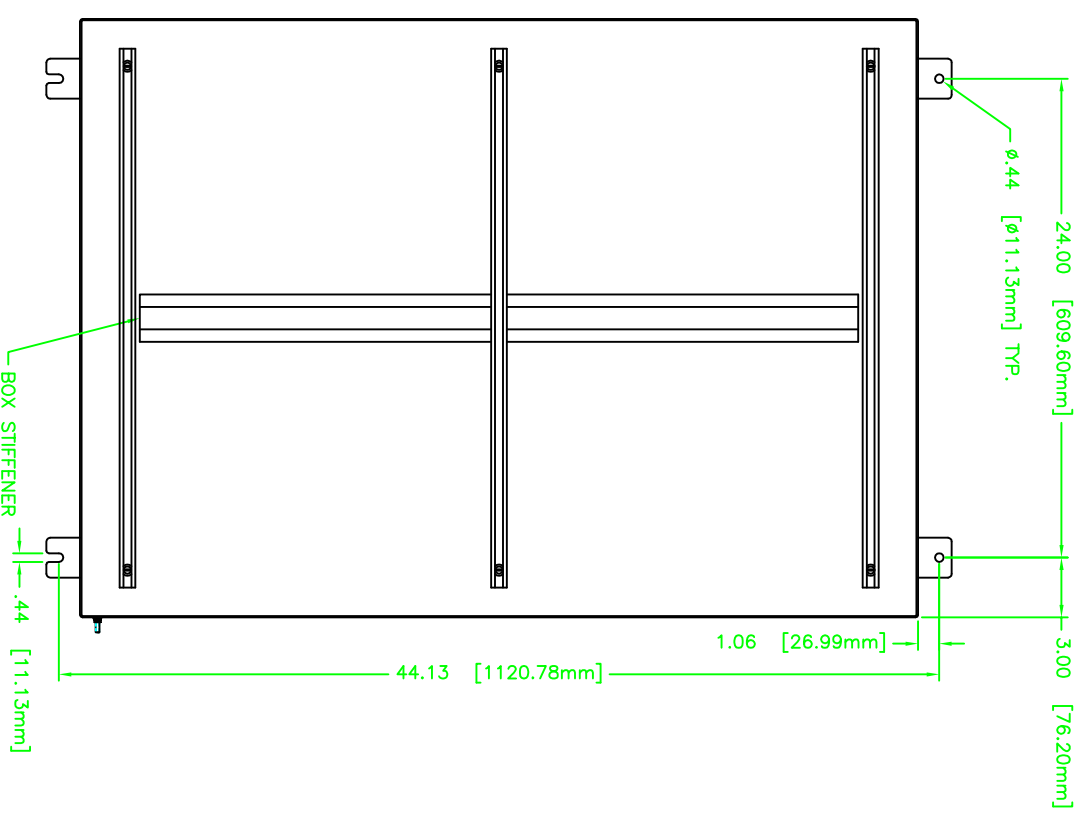
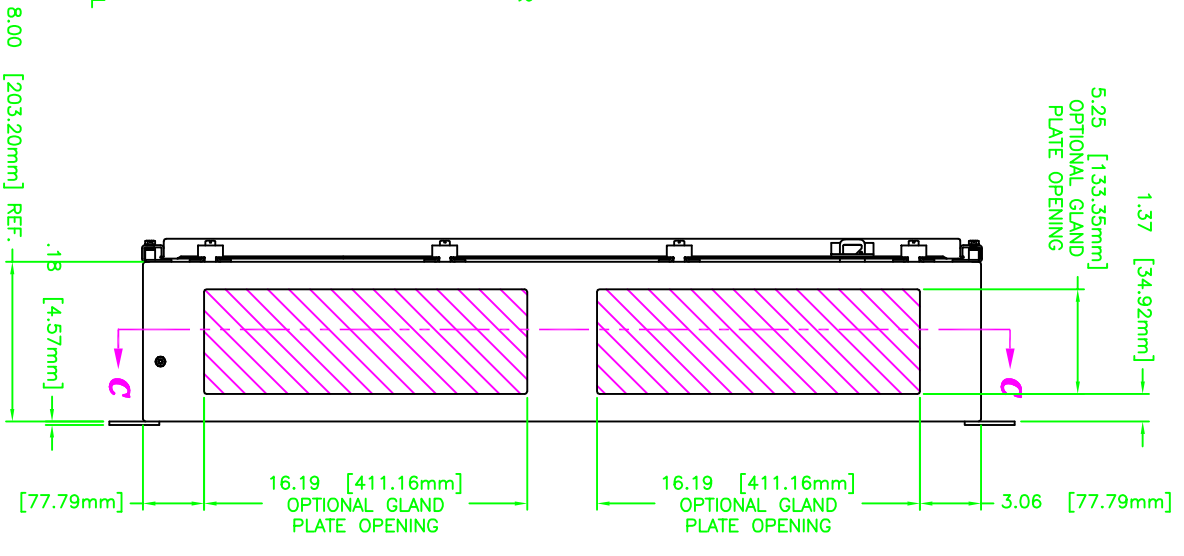
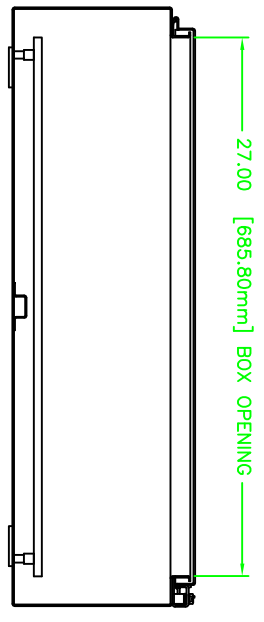
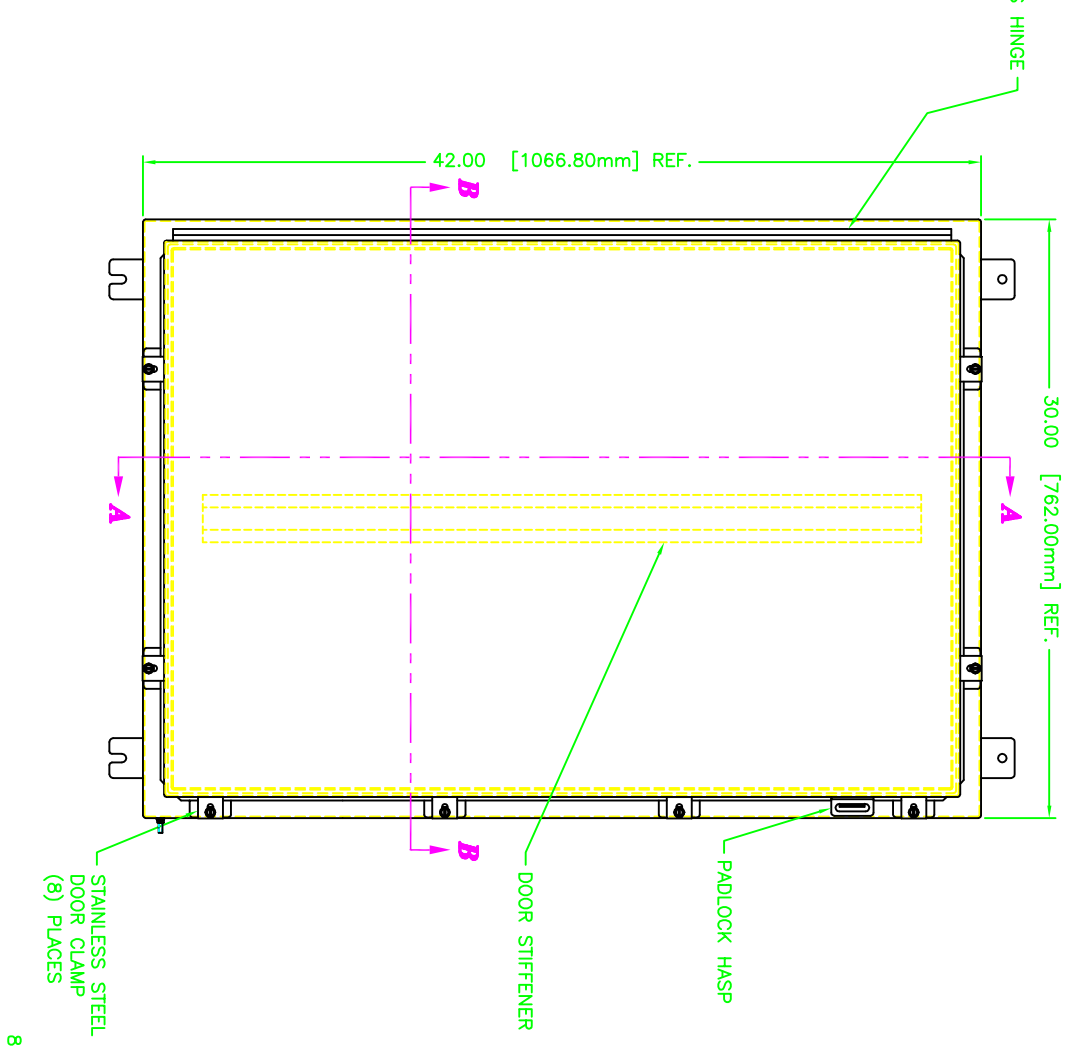
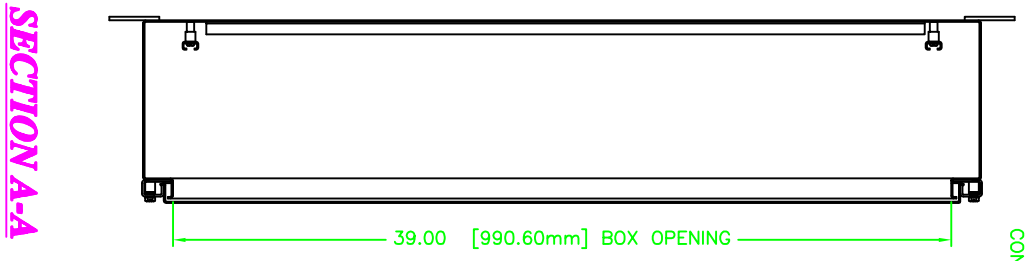
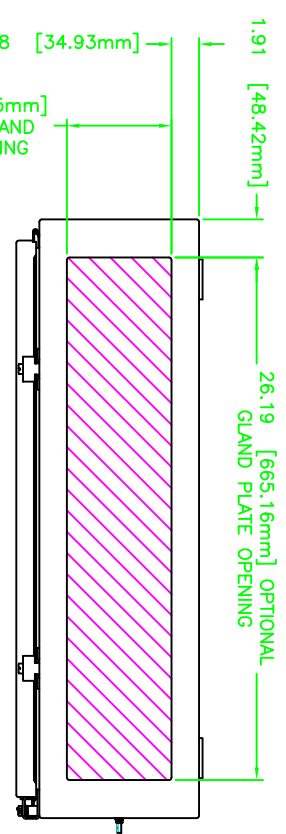

SECTION C-C

ENCLOSURE MATERIAL	CATALOG NUMBER	PART NUMBER
SS316L	TN4X6-423008U	M11184
SS304	TN4X-423008U	M11118

ADALET
 BUILDING AUTOMATIC SYSTEMS
 10000 WILSON ROAD, SUITE 100
 FARMERSVILLE, OHIO 43024
 TEL: 614-423-0088 FAX: 614-423-0089
 WWW.ADALET.COM

ADALET
 A SCOTT FITZGER COMPANY
 Building Automation
 10000 Wilson Road, Suite 100
 Farmersville, Ohio 43024
 Tel: 614-423-0088 Fax: 614-423-0089
 www.adalet.com

DESIGNED BY: [] DRAWN BY: []
 CHECKED BY: [] DATE: 12/23/08
 SCALE: 1=5
 SHEET NO: D
 PROJECT NO: 423008
 REV: 10F1 A