

REV	REVISION	BY	ECN	DATE
A	INITIAL RELEASE	CLB		12/2/08

363608

# UNCONTROLLED DRAWING

(DATA SUBJECT TO CHANGE WITHOUT NOTICE)

FOR ADDITIONAL HELP CONTACT ENGINEERING@ADALET.COM

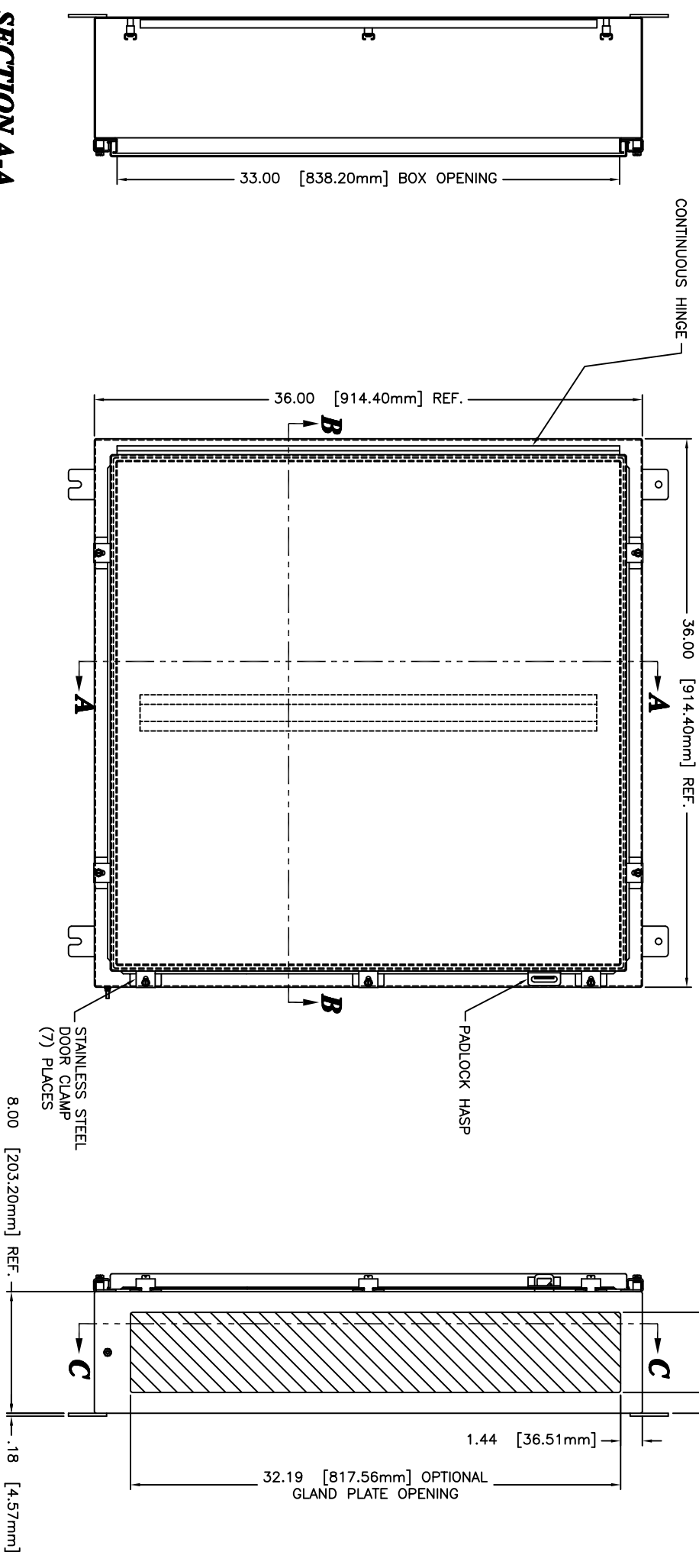
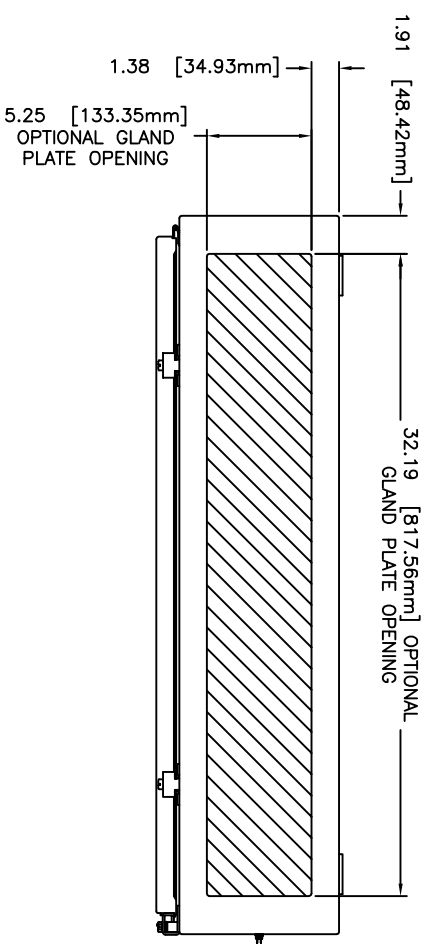

## SECTION C-C

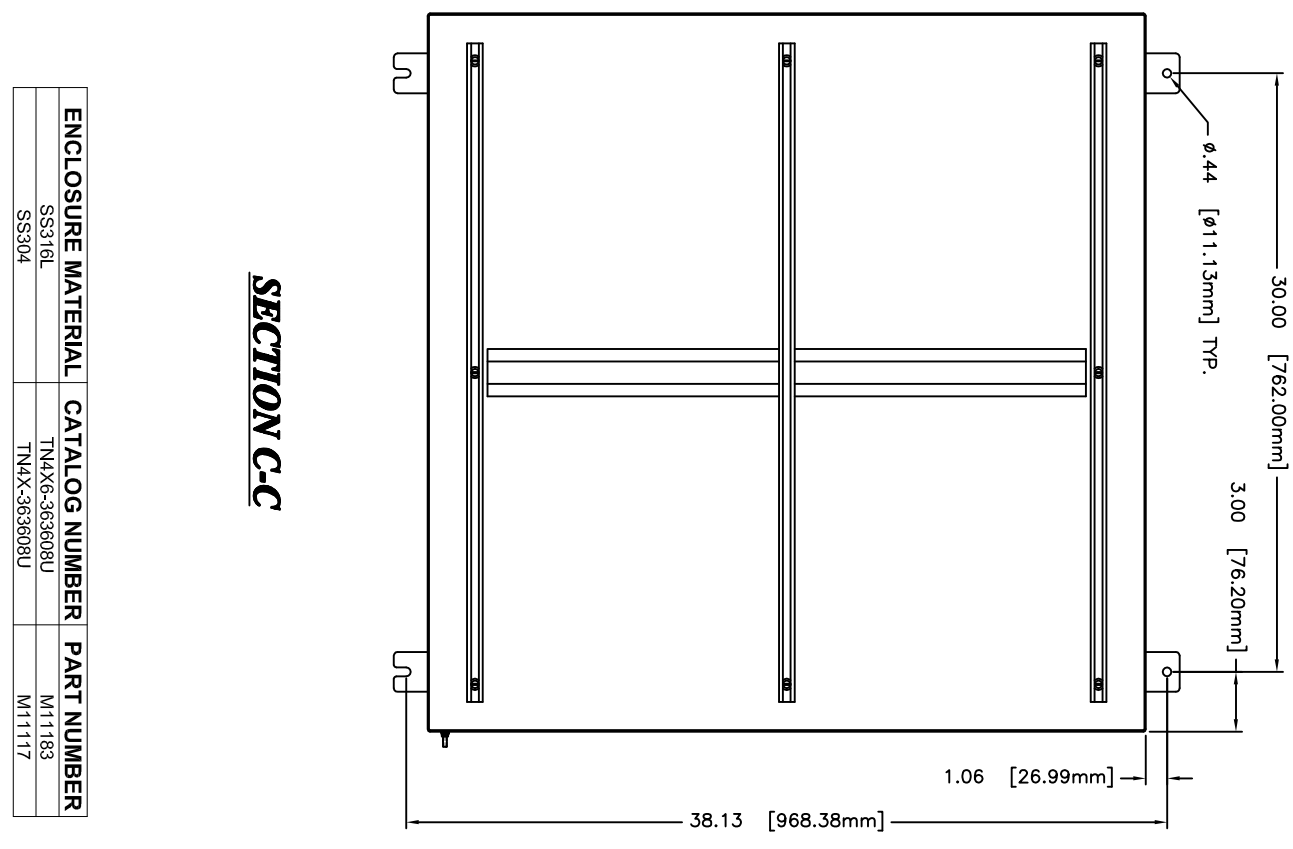

## SECTION B-B

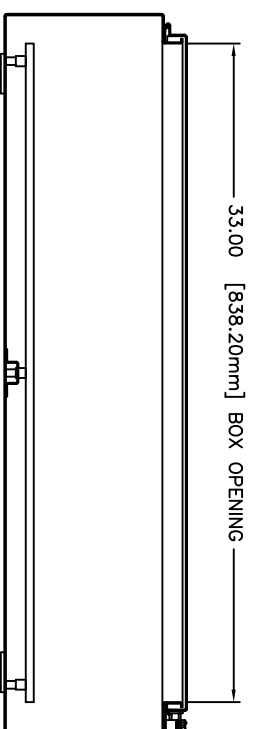

DO NOT SCALE DRAWING

UNLESS OTHERWISE SPECIFIED DIMENSIONS ARE IN INCHES

SELECT METAL TOLERANCES NOT OTHERWISE SPECIFIED:

FRACTIONAL ANGLES ± 0.005°

XX ± 0.01°

ANGLES ± 0.01°

MINOR END TOLERANCES ± 0.005 NOM

WARPAGE = 1/16" PER FOOT

ALL FIELD SIZES ARE NOM.

ADALET

SCOTT FITZGER COMPANY

4243925

12/3/08

ENCLOSURE

ASSSEMBLY

CLB

DATE

12/3/08

1=5

DWG SIZE

D

DWG NO

363608

REV

10F1

A