

363020

UNCONTROLLED DRAWING

(DATA SUBJECT TO CHANGE WITHOUT NOTICE)

FOR ADDITIONAL HELP CONTACT ENGINEERING@ADALEFT.COM

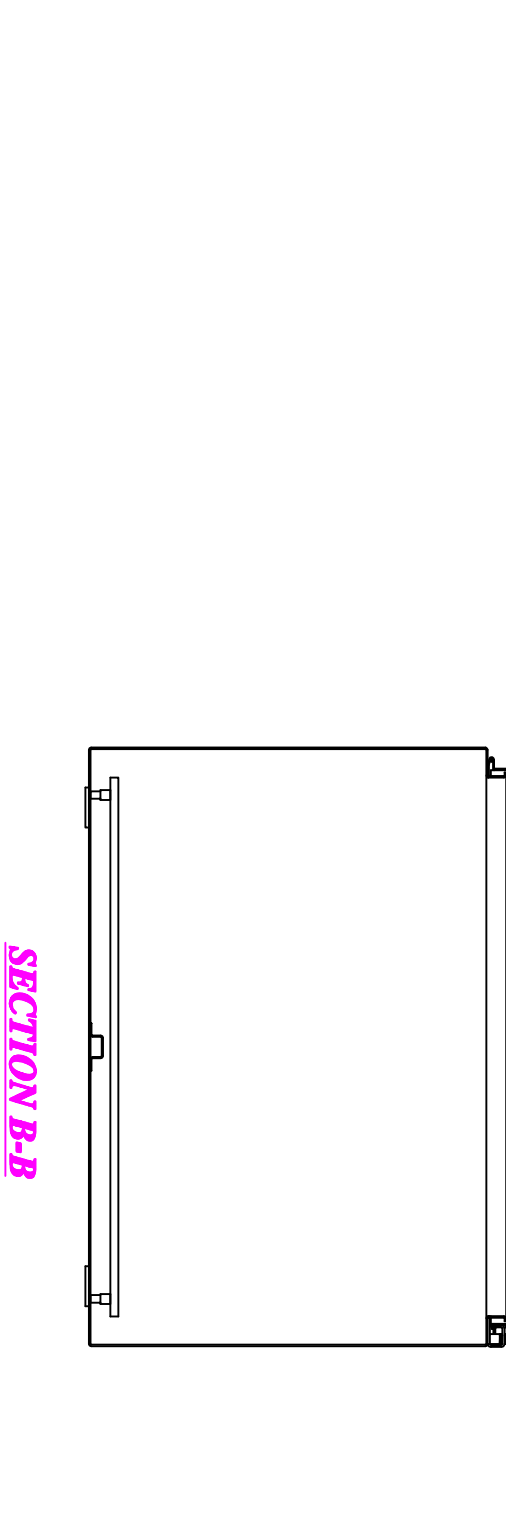
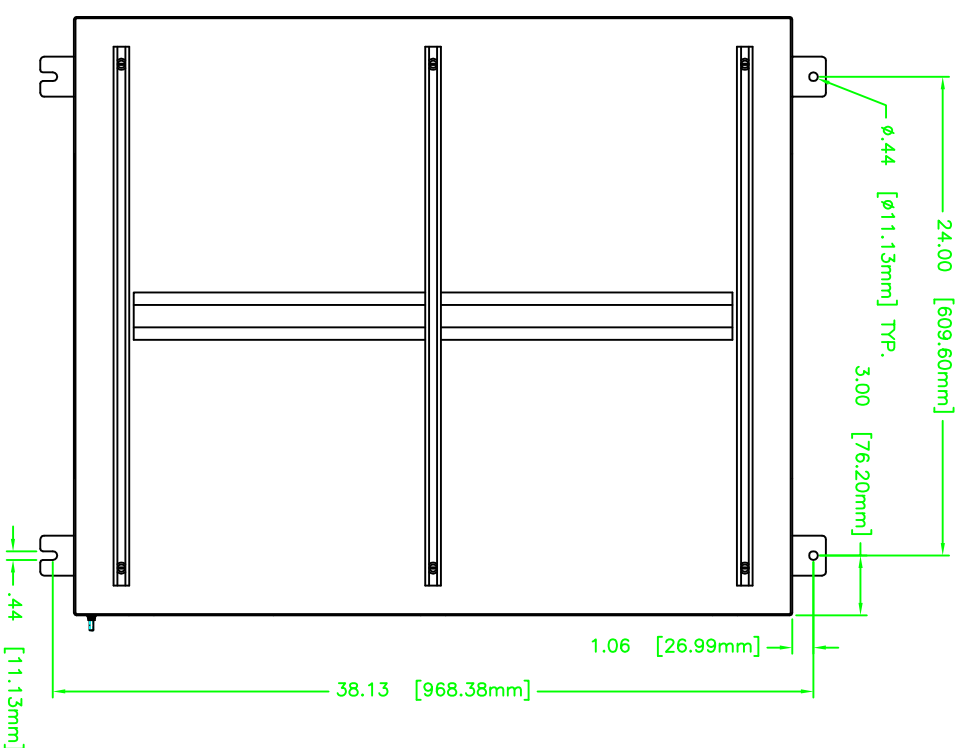
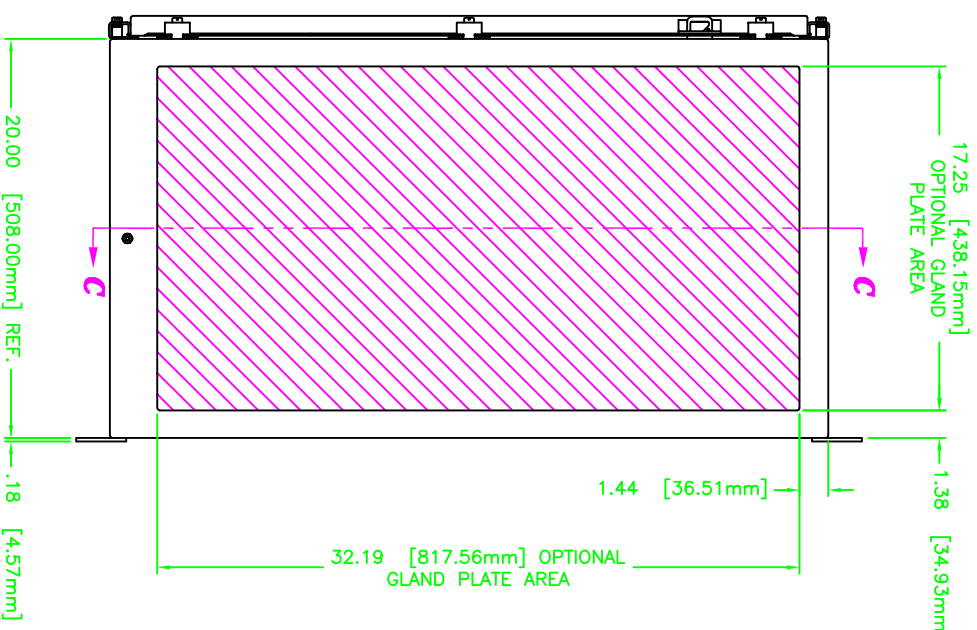
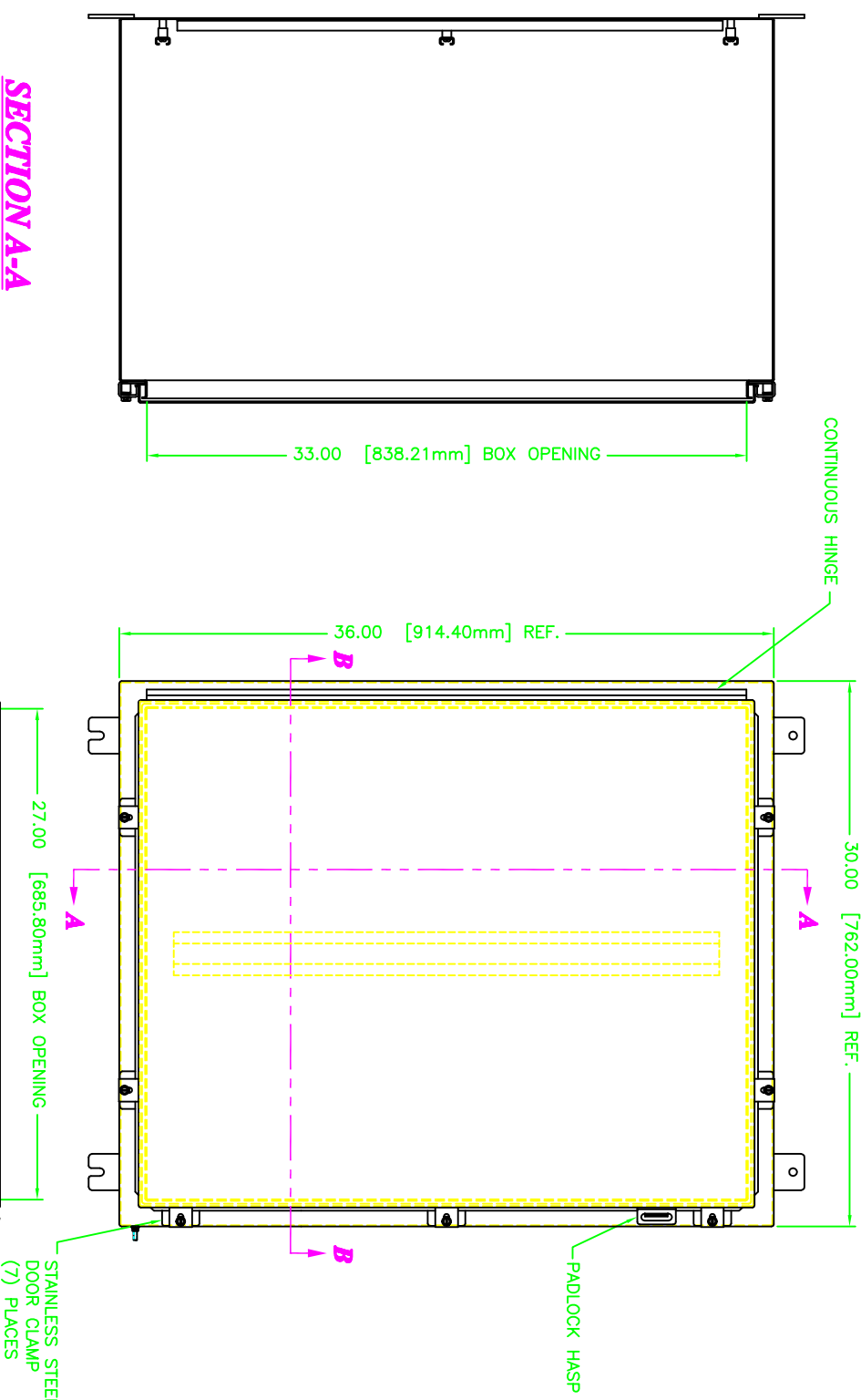
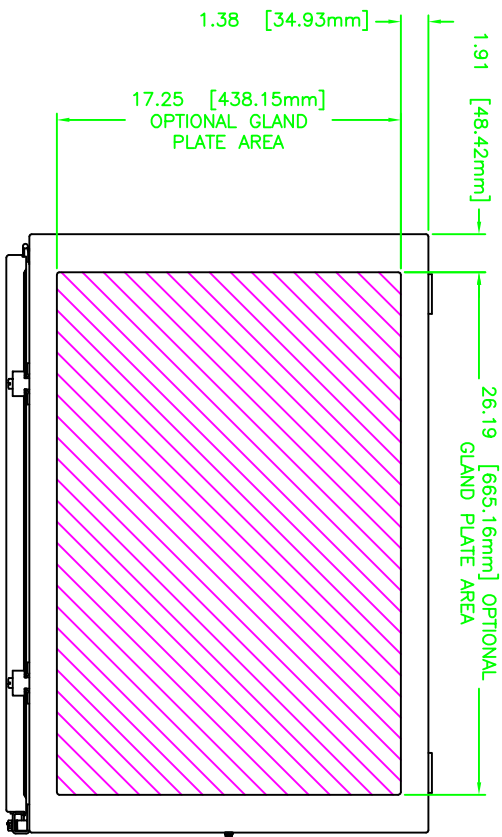

ENCLOSURE MATERIAL	CATALOG NUMBER	PART NUMBER
SS316L	TN4XG-363020U	M11423
SS304	TN4X-363020U	M11150

<p>ADALEFT A SCOTT FITZGER COMPANY Cleveland, Ohio 44135</p>		<p>TN4-363020 ENCLOSURE ASSEMBLY</p>	
<p>NO NOT SCALE DRAWING DIMENSIONS SHOWN IN INCHES SELECT METRIC TOLERANCES NOT OTHERWISE SPECIFIED: FRACTIONS: 1/16" XX ± .03" XXX ± .01" ANGLES: 30°-90° HIDDEN DIMENSIONS: 0.00" MINIMUM DIMENSIONS: 0.00" WELDING: 1/16" PER FOOT ALL FIELD SIZES ARE MIN.</p>	<p>FOR ADDITIONAL HELP CONTACT ENGINEERING@ADALEFT.COM</p>	<p>DATE: 12/3/08 SCALE: 1=5 DWT: D</p>	<p>REV: 10F1 A</p>