

363012

UNCONTROLLED DRAWING

(DATA SUBJECT TO CHANGE WITHOUT NOTICE)

FOR ADDITIONAL HELP CONTACT ENGINEERING@ADALETT.COM

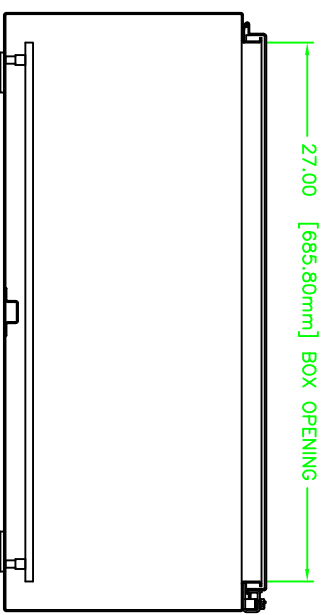
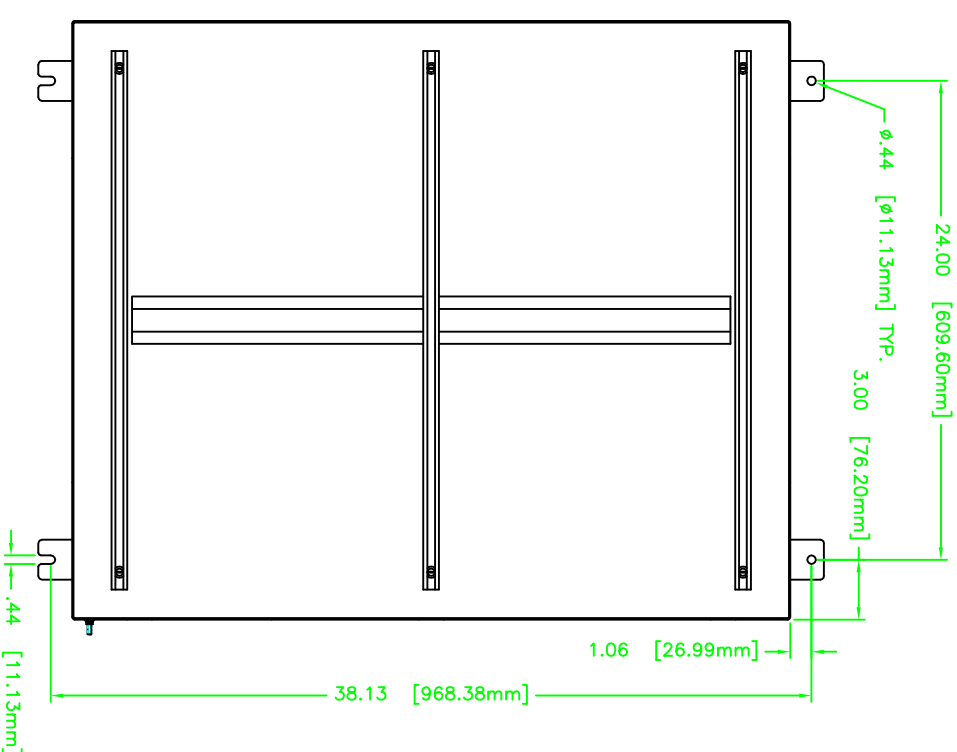
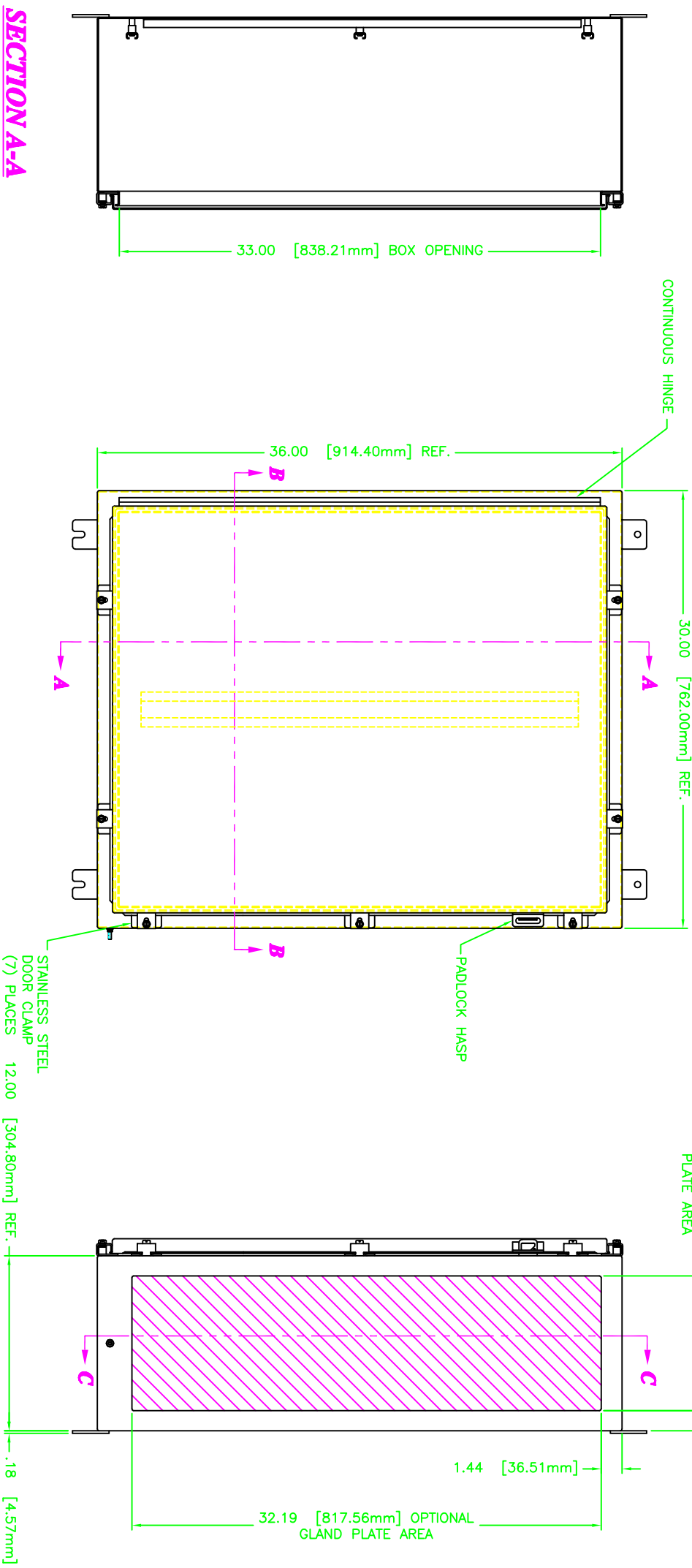
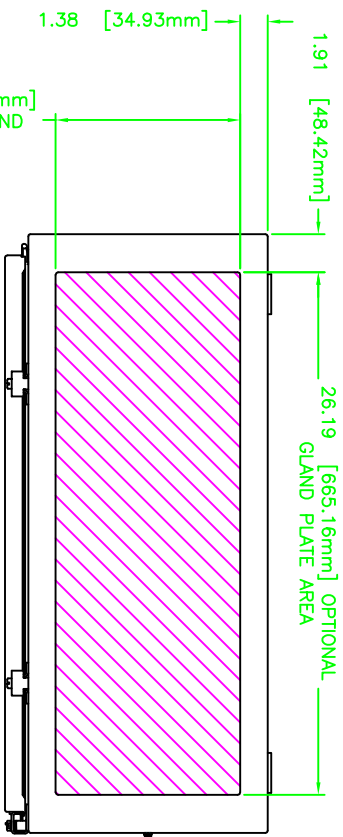

SECTION C-C

ENCLOSURE MATERIAL	CATALOG NUMBER	PART NUMBER
SS316L	TN4XG-363012U	M11409
SS304	TN4X-363012U	M11138

DO NOT SCALE DRAWING		DATE	
UNLESS OTHERWISE SPECIFIED DIMENSIONS ARE IN INCHES	ADALETT	TN4-363012 ENCLOSURE ASSEMBLY	12/3/08
SHEET METAL TOLERANCES NOT OTHERWISE SPECIFIED:	Richard A. Scott Fitzler Company Cleveland, OH 44135	CLB	12/3/08
FINE 31/64"	WORK TO BEING ISSUED THE DRAWING	DATE	12/3/08
COARSE 3/32"	ISSUED AS SHOWN	REV SCALE	1=5
XXX ± .01"	FOR DIMENSIONS IN PARENTHESES	DWG SIZE	D
ANGLES ± 0°-30'	FOR DIMENSIONS IN PARENTHESES	DWG NO.	363012
FINISHES: SEE DWG. NOTES	FOR DIMENSIONS IN PARENTHESES	REV	10F1 A
WELDING: SEE DWG. NOTES	FOR DIMENSIONS IN PARENTHESES	DATE	
ALL FIELD SIZES ARE MIN.	FOR DIMENSIONS IN PARENTHESES		