

363010

UNCONTROLLED DRAWING

(DATA SUBJECT TO CHANGE WITHOUT NOTICE)

FOR ADDITIONAL HELP CONTACT ENGINEERING@ADALEFT.COM

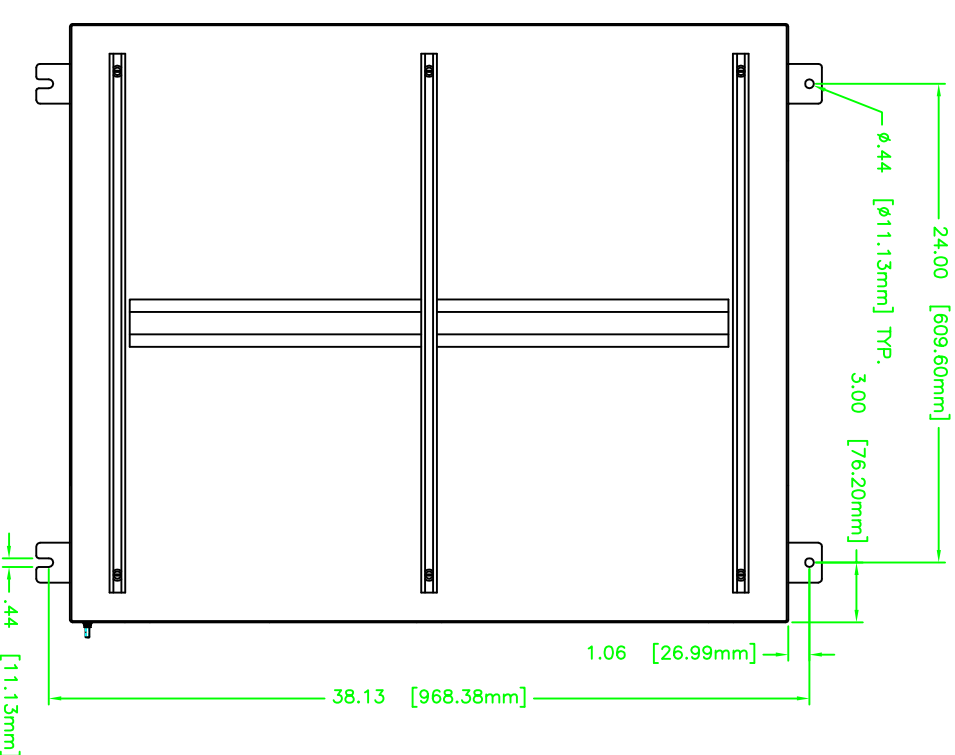
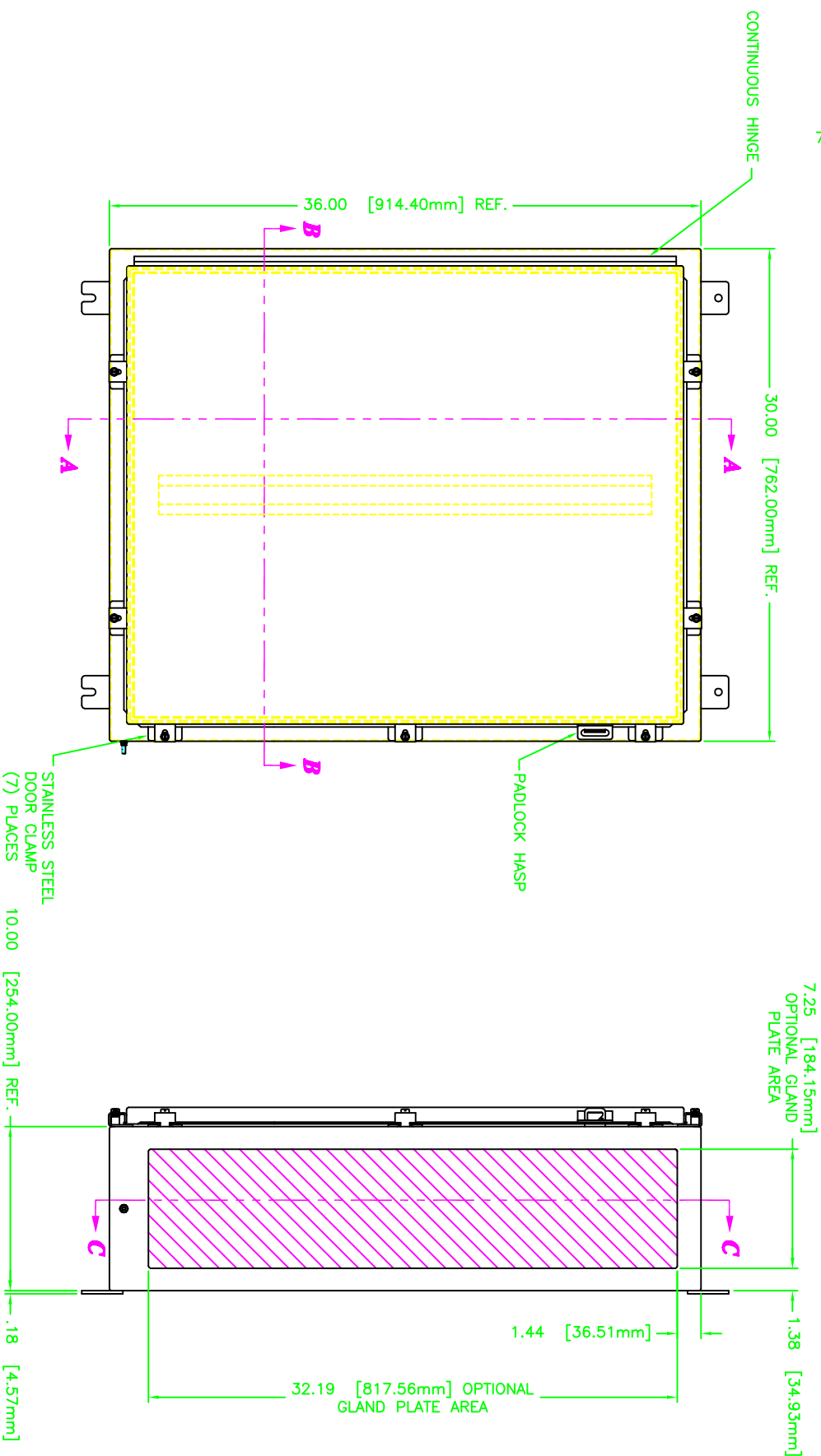
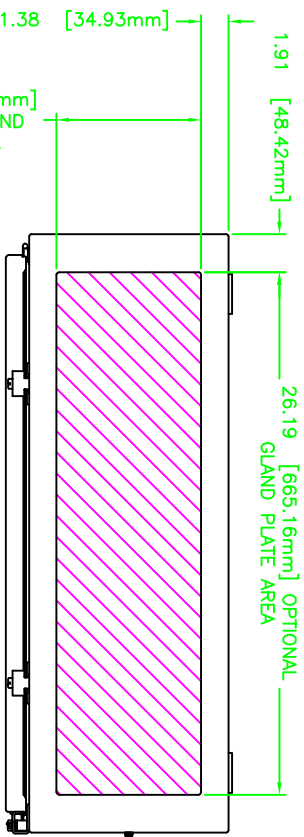

SECTION C-C

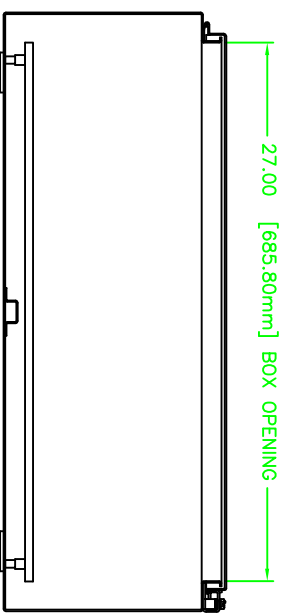

SECTION B-B

ENCLOSURE MATERIAL	CATALOG NUMBER	PART NUMBER
SS316L	TN4XG-363010U	M11193
SS304	TN4X-363010U	M11127

<p>ADALEFT BUILDING OPERATIONS SERVICES 10000 W. 10th Street, Suite 100 Westminster, CO 80040 Phone: 303.426.4335 Fax: 303.426.4336 Email: sales@adaleft.com</p>		<p>TN4-363010 ENCLOSURE ASSEMBLY</p>	
<p>NO HOT SPARK DRAWING DIMENSIONS ARE IN INCHES SELECT METRIC TOLERANCES NOT OTHERWISE SPECIFIED: FRACTIONS ± 1/16" DECIMALS ± 0.01" ANGLES ± 0°-30" HOLE POSITION ± 0.005" HOLE SIZE ± 0.001" HOLE POSITION ± 0.005" HOLE SIZE ± 0.001" ALL HOLE SIZES ARE DIA.</p>		<p>DATE: 12/3/08 DRAWN BY: CLB CHECKED BY: JWB SCALE: 1=5 SHEET: D OF: 1</p>	
<p>CAT NO: 363010</p>		<p>REV: 10F1 A</p>	