

REV	REVISION	BY	CHK	DATE
A	INITIAL RELEASE	TT		12/2/08

302406

UNCONTROLLED DRAWING

(DATA SUBJECT TO CHANGE WITHOUT NOTICE)
FOR ADDITIONAL HELP CONTACT ENGINEERING@ADALIST.COM

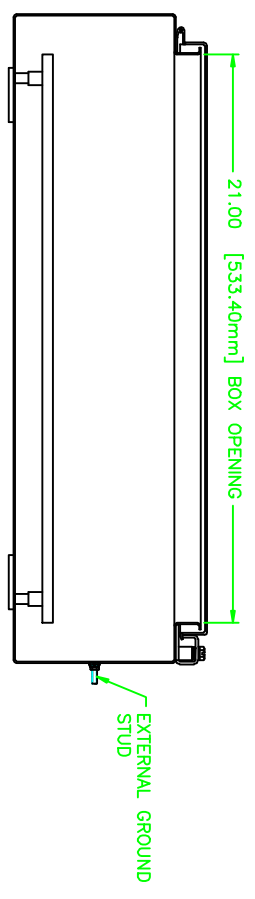
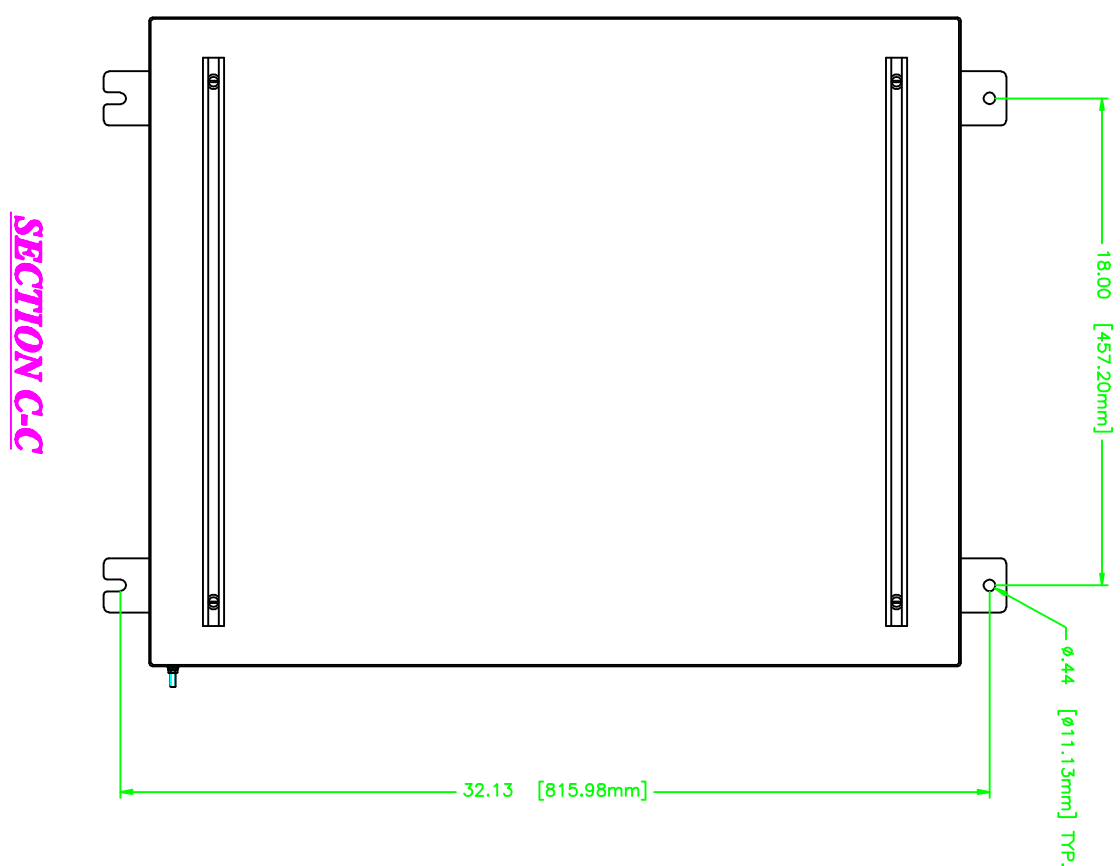
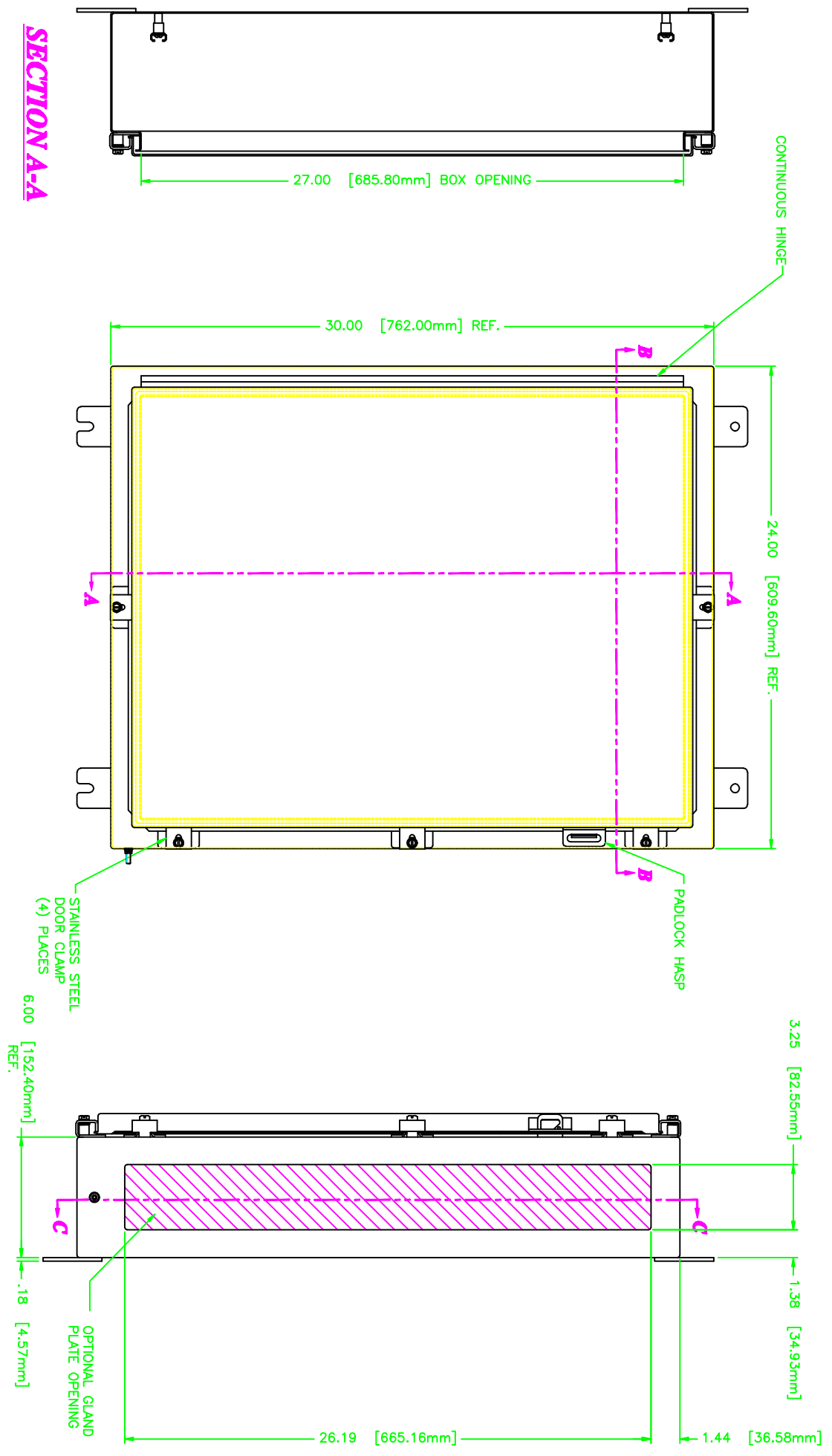
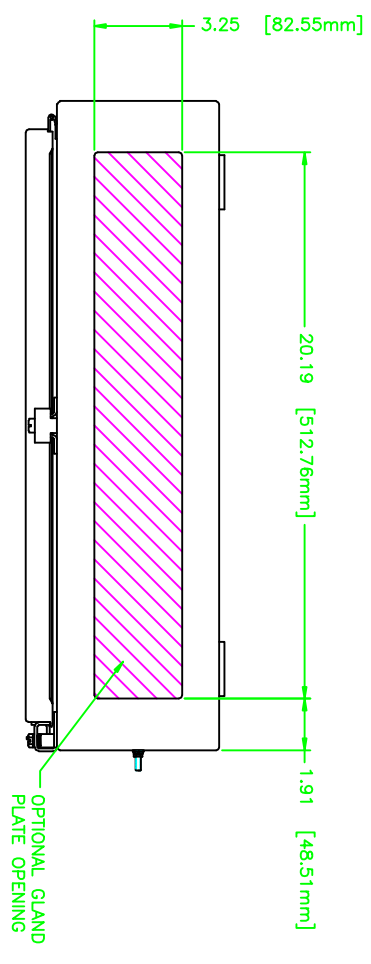

ENCLOSURE MATERIAL	CATALOG NUMBER	PART NUMBER
SS316L	TN4XG-302406JU	M11166
SS304	TN4X-302408JU	M11099

ADALIST
SPECIALTY SYSTEMS, INC.
Engineering Systems, Cable Accessories

DO NOT SCALE DRAWINGS
DIMENSIONS ARE TO CENTER
SHEET METAL, UNLESS
NOT OTHERWISE SPECIFIED:
FINISH: 316
CORNER RADIUS: .0625"
HOLE FINISH: 125 RA
WELD FINISH: 125 RA
ALL WELD SIZES ARE 1/8"

NOTE TO PERSON RECEIVING THIS DRAWING:
REPRODUCED HEREIN, THE DRAWING IS THE PROPERTY
OF ADALIST SYSTEMS, INC. AND IS TO BE USED
ONLY FOR THE PROJECT AND SITE SPECIFICALLY
IDENTIFIED. IT IS NOT TO BE REPRODUCED,
COPIED, OR TRANSMITTED IN ANY FORM OR
BY ANY MEANS, ELECTRONIC OR MECHANICAL,
INCLUDING PHOTOCOPYING, RECORDING, OR
BY ANY INFORMATION STORAGE AND RETRIEVAL
SYSTEM, WITHOUT THE WRITTEN PERMISSION
OF ADALIST SYSTEMS, INC.

TN4-302406 ENCLOSURE ASSEMBLY

DATE	BY	CHK	APP
12/3/08	TT		
1=3.5			
D			

302406 10F1 A