

REV	DESCRIPTION	BY	DATE
A	INITIAL RELEASE	TT	12/2/08

242410

UNCONTROLLED DRAWING

(DATA SUBJECT TO CHANGE WITHOUT NOTICE)
 FOR ADDITIONAL HELP CONTACT ENGINEERING@ADALIST.COM

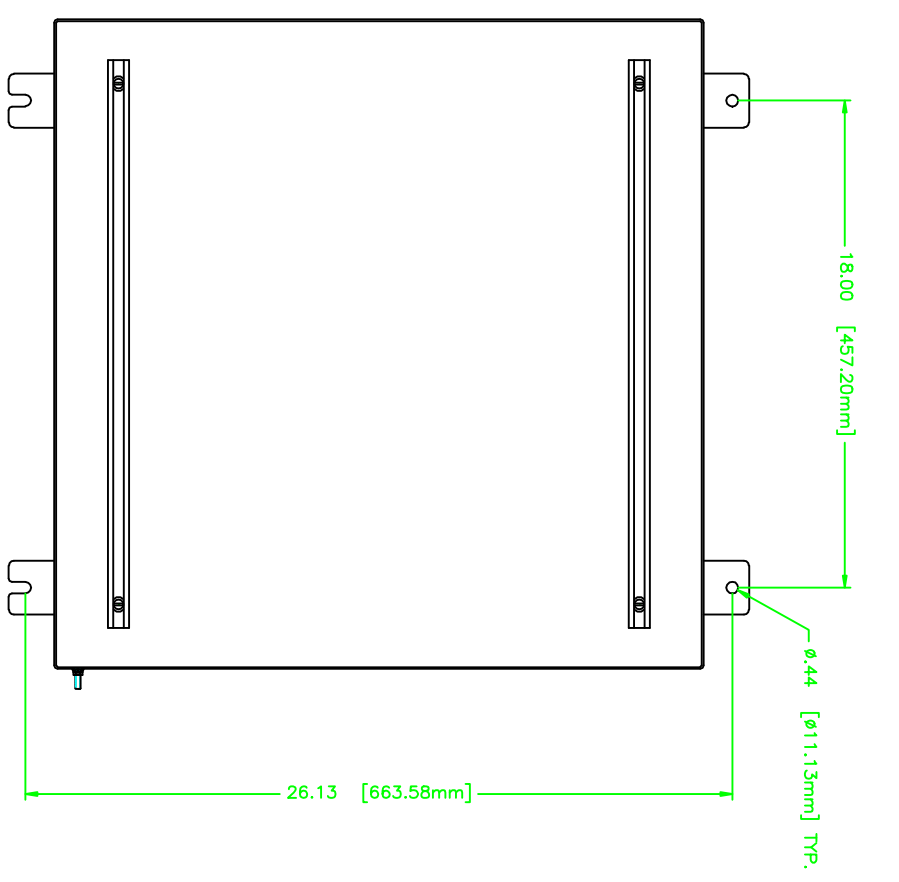
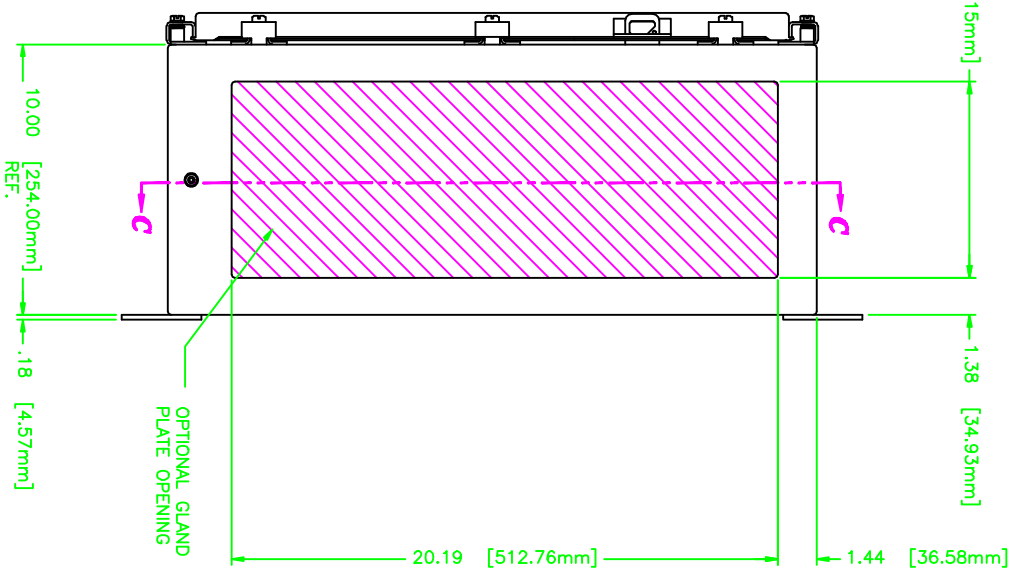
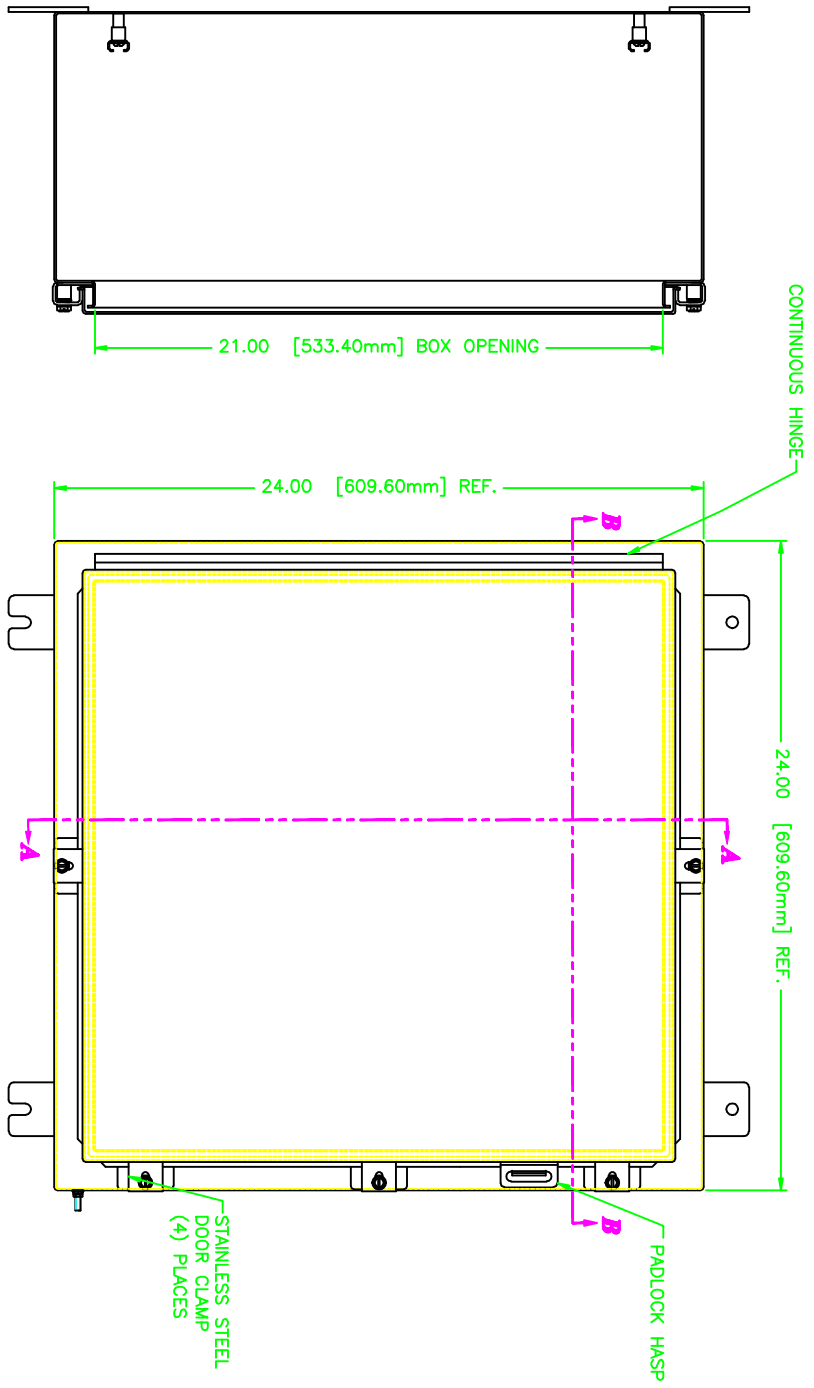
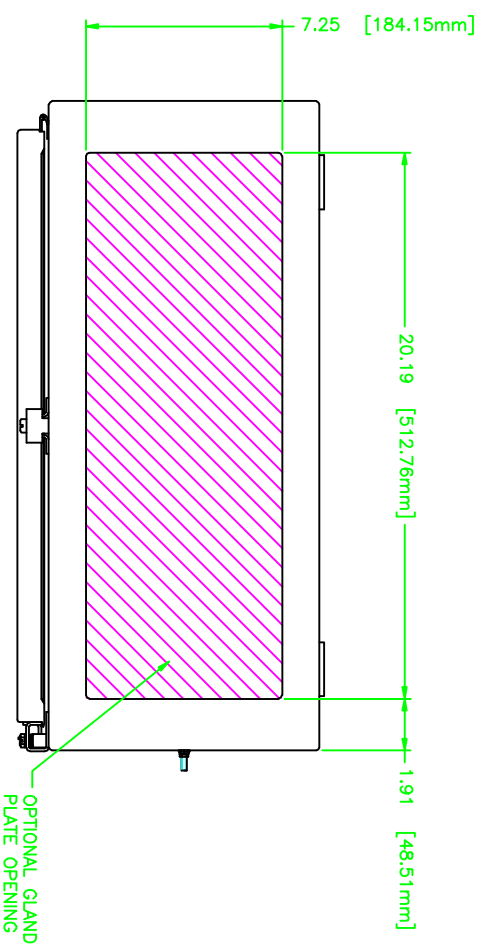

SECTION A-A

SECTION B-B

SECTION C-C

ENCLOSURE MATERIAL	CATALOG NUMBER	PART NUMBER
SS316L	TN4XG-242410U	M11190
SS304	TN4X-242410U	M11124

ADALIST
 SYSTEMS
 24133

ENGINEERING

242410 ENCLOSURE ASSEMBLY

12/3/08

1=3.5

242410 10F1 A