

REV	REVISION	BY	ECN	DATE
A	INITIAL RELEASE	CB		8/15/03
B	8-3/4" MTG PAN DIM WAS 8-7/8"	CB		2/23/04

080804

UNCONTROLLED DRAWING

(DATA SUBJECT TO CHANGE WITHOUT NOTICE)
FOR ADDITIONAL HELP CONTACT ENGINEERING@ADALFT.COM

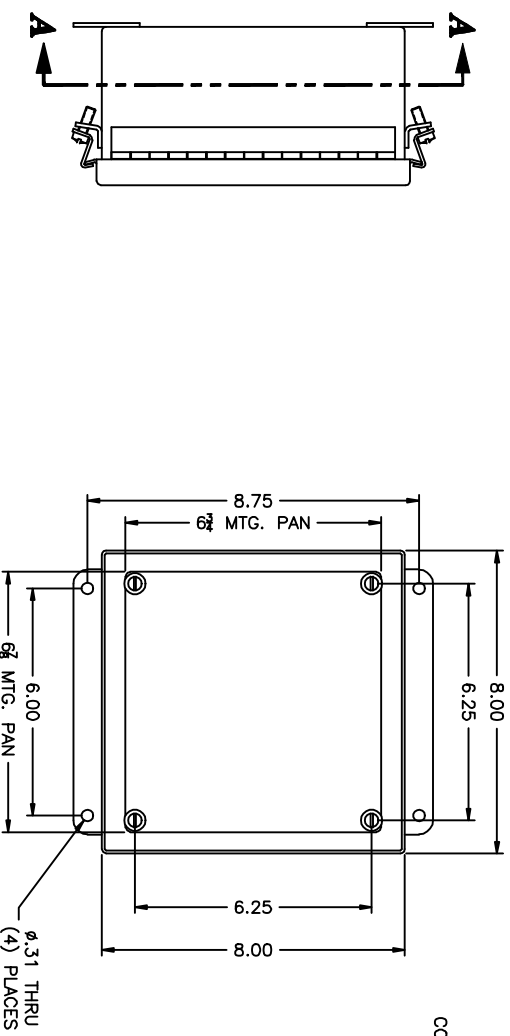
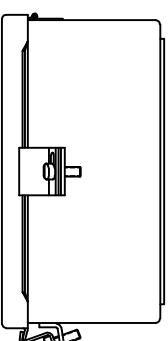

SECTION A-A

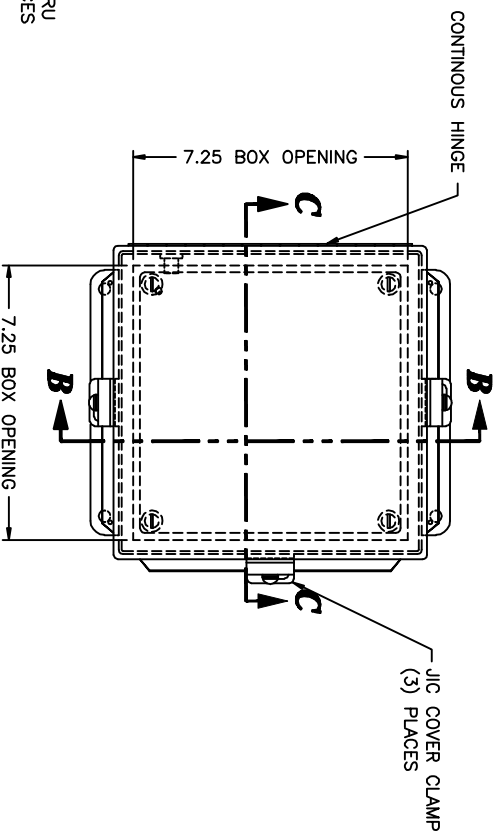

SECTION B-B

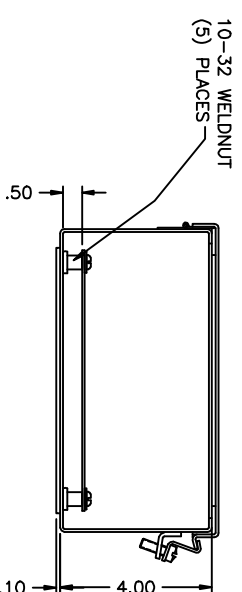
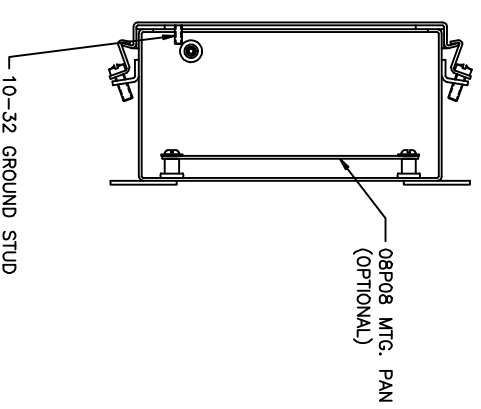

SECTION C-C

ENCLOSURE MATERIAL	CATALOG NUMBER	PART NUMBER
SS316L	JN4XHSS6-080804	M10336
SS304	JN4XHSS-080804	M10306

DO NOT SCALE DRAWING		DATE	
<p>THIS DRAWING IS THE PROPERTY OF ADALFT. IT IS TO BE USED ONLY FOR THE PROJECT AND FOR THE CLIENT'S USE. IT IS NOT TO BE REPRODUCED, COPIED, OR TRANSMITTED IN ANY FORM OR BY ANY MEANS, ELECTRONIC OR MECHANICAL, WITHOUT THE WRITTEN PERMISSION OF ADALFT.</p> <p>ADALFT Engineering Systems, Cable Accessories 2441330</p>	<p>JN4XHSS-080804 JIC ASSEMBLY</p>	<p>DATE: 8/15/03</p>	<p>BY: D</p>
<p>DESIGNER: CLB</p>	<p>DATE: 8/15/03</p>	<p>BY: D</p>	<p>DATE: 8/15/03</p>
<p>DATE: 080804</p>	<p>BY: D</p>	<p>DATE: 10F1</p>	<p>BY: B</p>