

REV	REVISION	BY	ECN	DATE

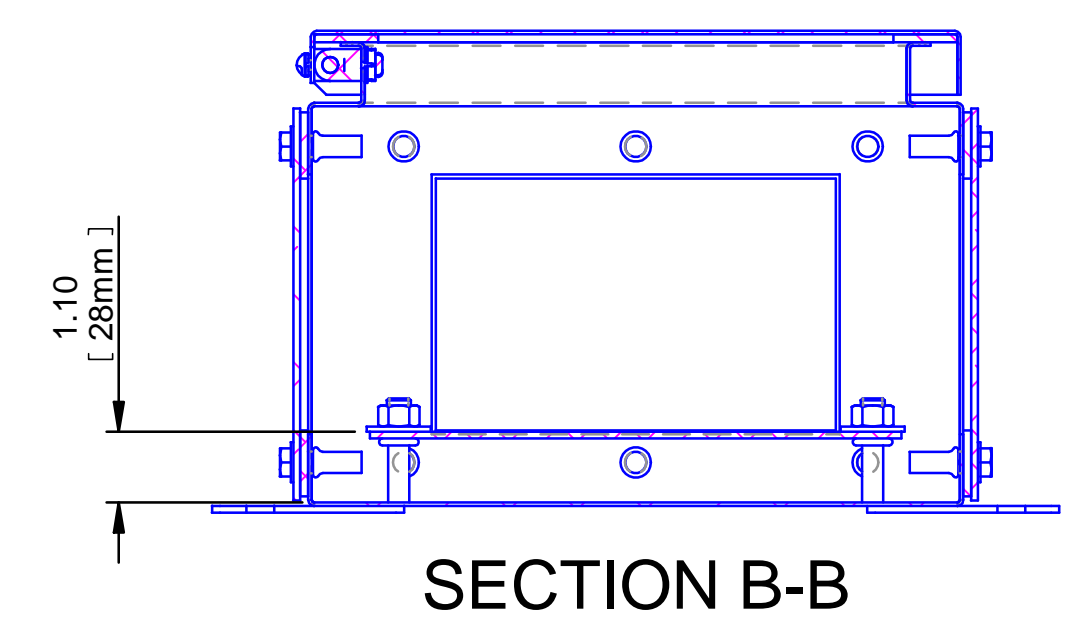
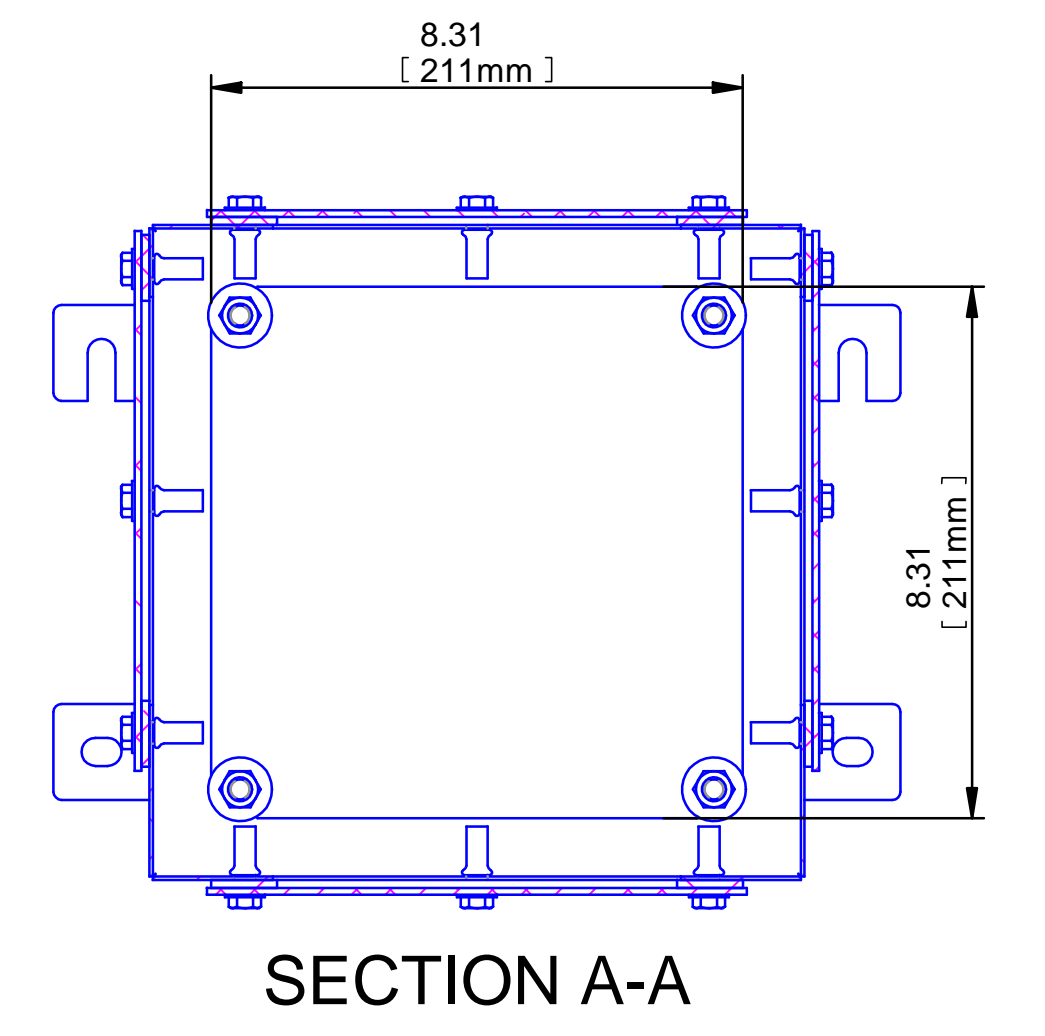
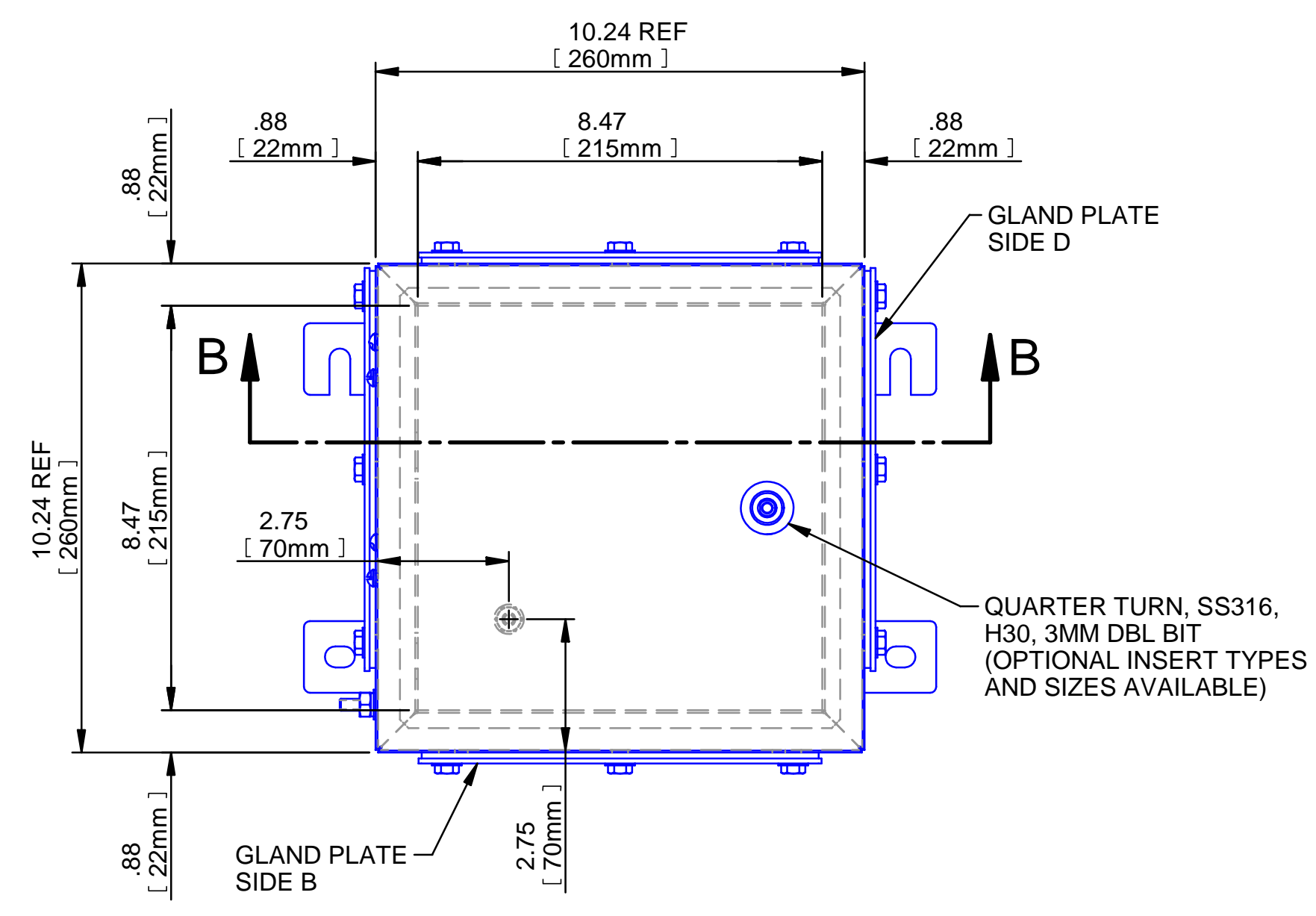
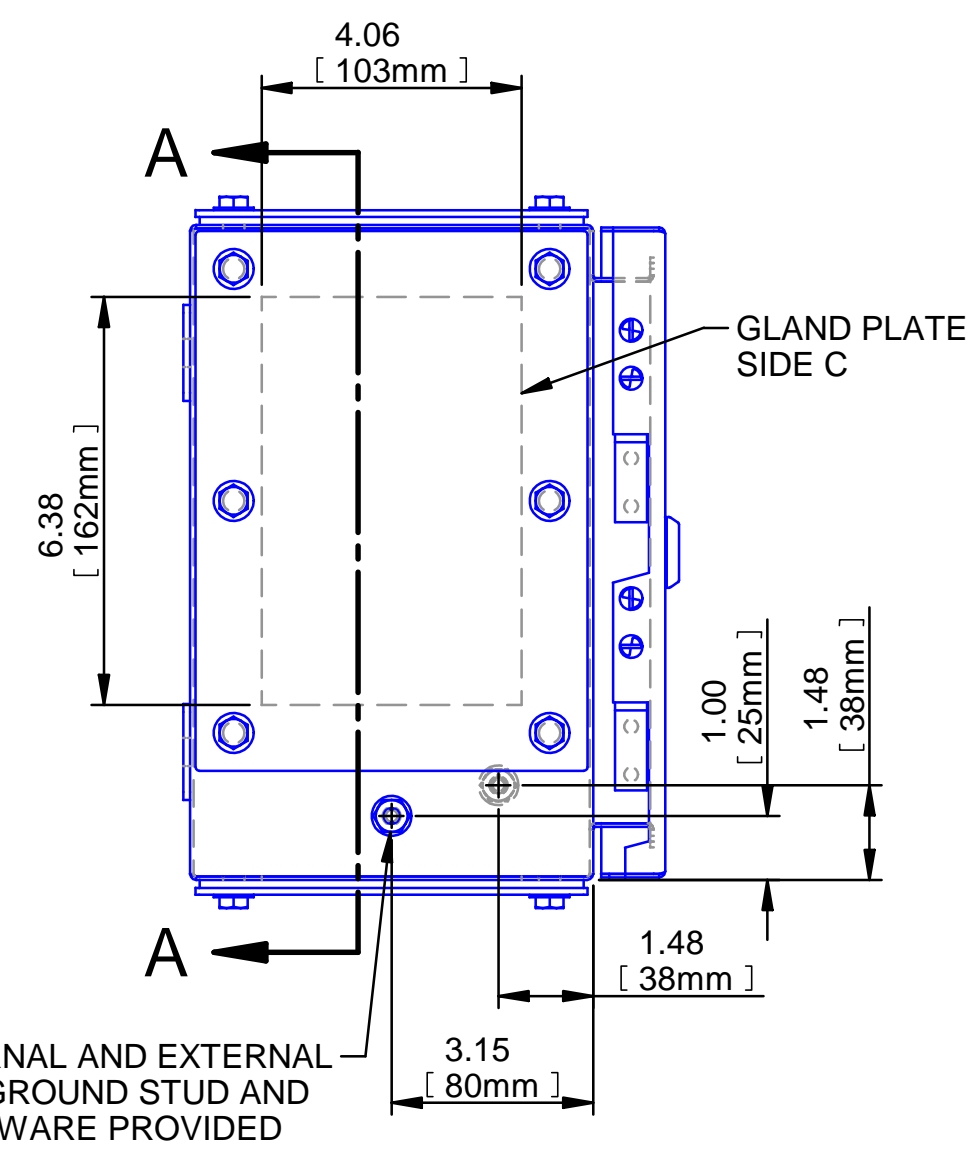
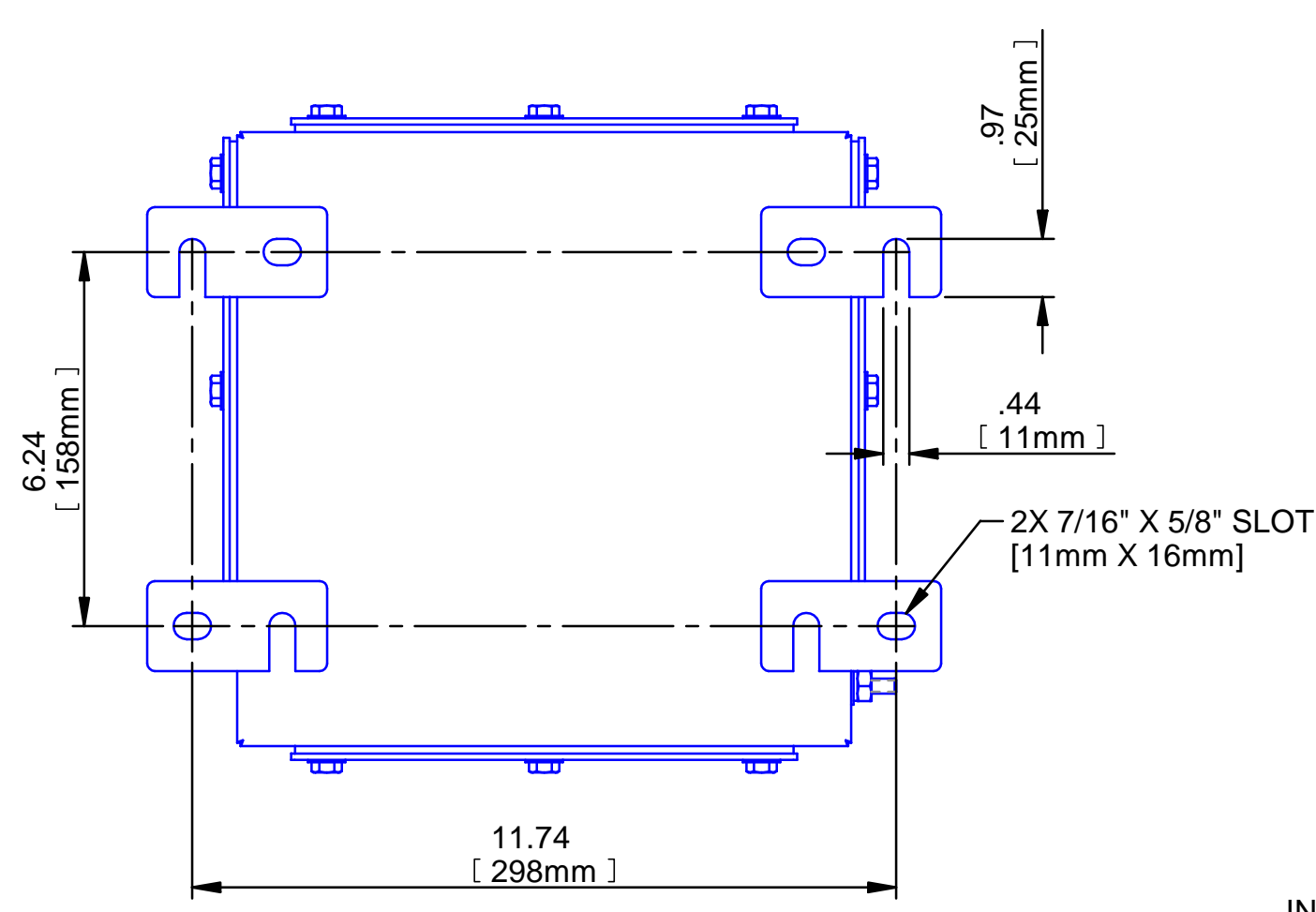
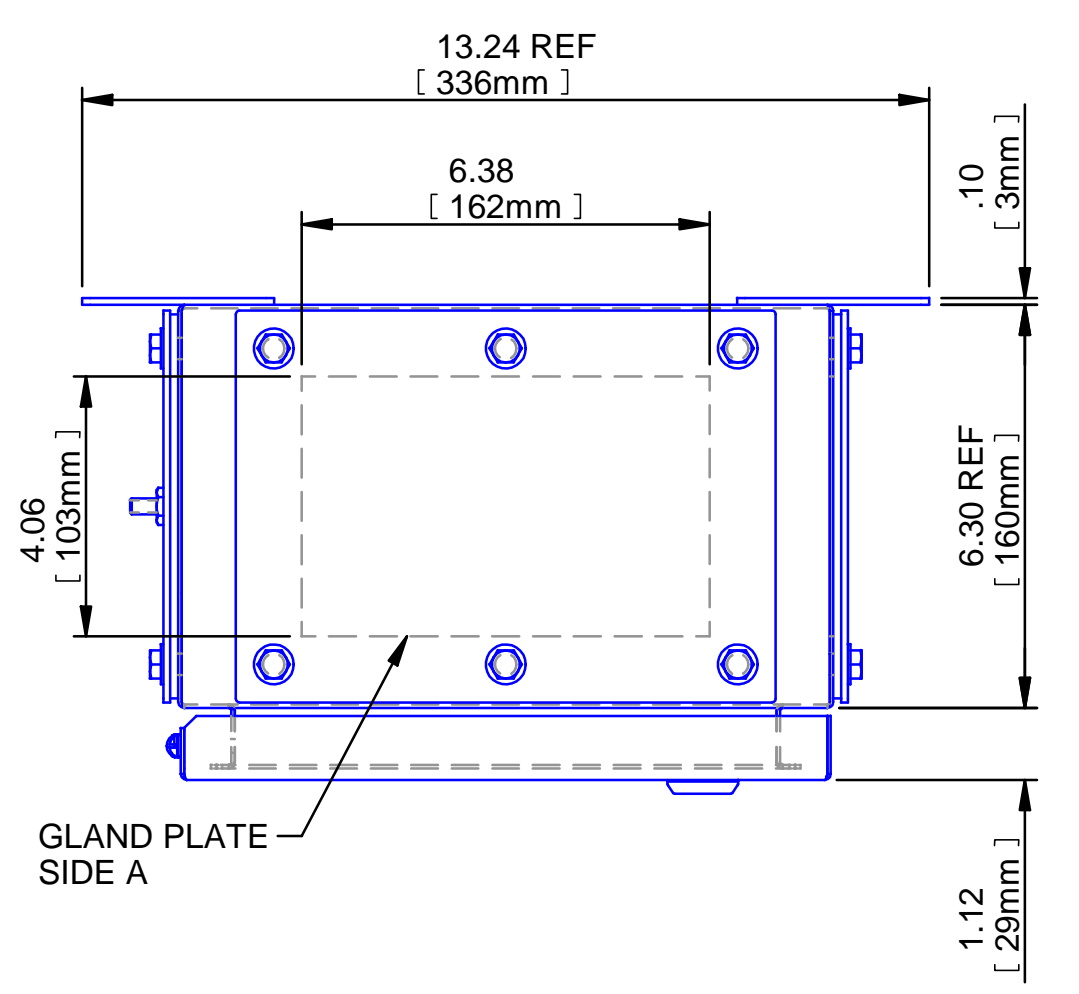
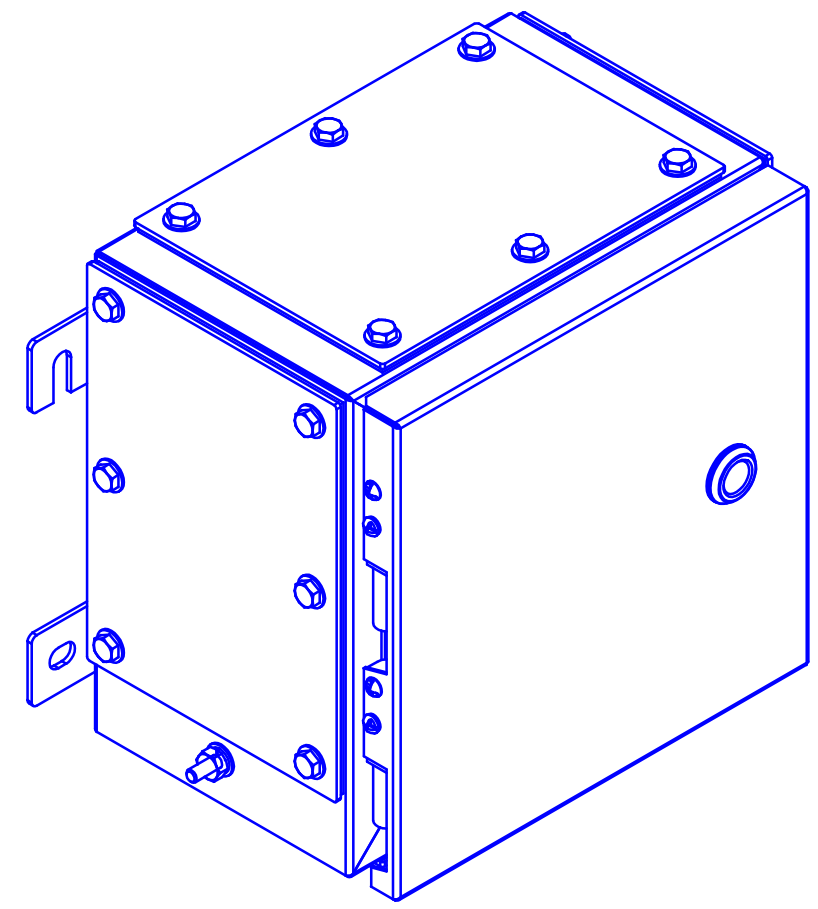

UNCONTROLLED DRAWING
(DATA SUBJECT TO CHANGE
WITHOUT NOTICE)

**DO NOT REVISE THIS DWG. IN AUTOCAD
3D GENERATED IN SOLID EDGE**

<small>DO NOT SCALE DRAWING UNLESS OTHERWISE SPECIFIED DIMENSIONS ARE IN INCHES CAST TOLERANCES ON DIMENSIONS NOT OTHERWISE SPECIFIED: 1/8" STOCK FILLET OR CORNER RADI 1/8" DRAFT 1:12 FRAC ±1/16" ANGLES ±1° MACHINE TOLERANCES ON DIMENSIONS NOT OTHERWISE SPECIFIED: √ = 125 MIN X.X ± .03 X.XX ± .010" FILLET RADI .03" EDGE BREAK .035"-.015" R. or 45° ANGLES ± 0°30' DRAFTING FOR THREADED HOLES NOT OTHERWISE SPECIFIED: MPT E-21-2.6 NPSM E-24-1.0</small>				<small>NOTICE TO PERSONS RECEIVING THIS DRAWING: ADALET-PLM CLAIMS PROPRIETARY RIGHTS IN THE MATERIAL DISCLOSED HEREIN. THIS DRAWING IS ISSUED IN CONFIDENCE FOR ENGINEERING INFORMATION ONLY AND MAY NOT BE REPRODUCED OR USED TO MANUFACTURE ANYTHING SHOWN HEREON, WITHOUT DIRECT WRITTEN PERMISSION FROM ADALET-PLM TO THE USER.</small>		<small>TITLE</small> VH-262616 INCREASED SAFETY ENCLOSURE CUSTOMER OUTLINE DRAWING	
<small>FINISH</small> CAT NO		<small>DRAWN BY</small> DMS		<small>DATE</small> 12/4/2008		<small>ENG APPROVAL</small> 	
<small>MATERIAL</small>		<small>MFG APPROVAL</small>		<small>PLOT SCALE</small> 1=3		<small>DWG SIZE</small> D	
<small>DWG NO</small>		<small>SHT</small>		<small>REV</small>			