

REV	REVISION	BY	ECN	DATE
A	INITIAL RELEASE	CB		8/19/03
B	8-3/4 MTG PAN DIM WAS 8-7/8	CB		2/23/04

080604

# UNCONTROLLED DRAWING

(DATA SUBJECT TO CHANGE WITHOUT NOTICE)  
FOR ADDITIONAL HELP CONTACT ENGINEERING@ADALFT.com

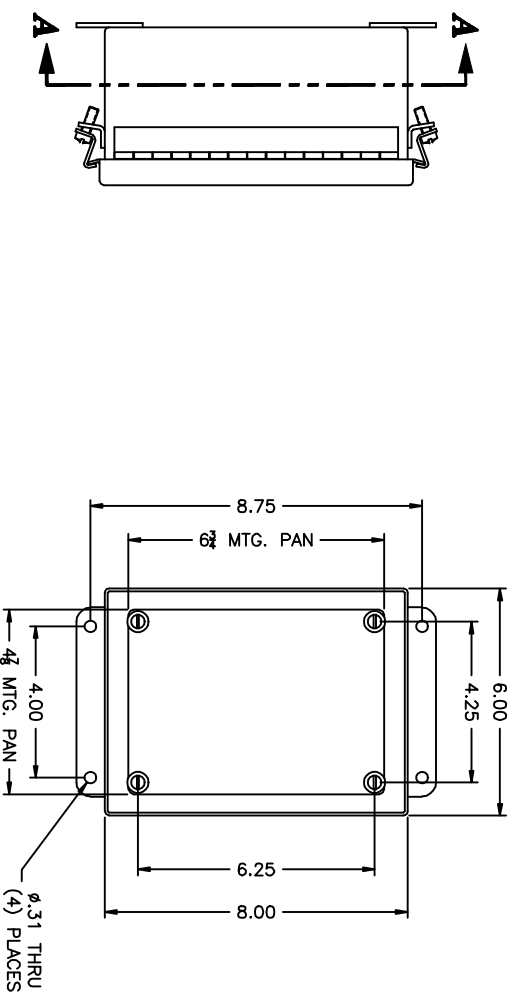
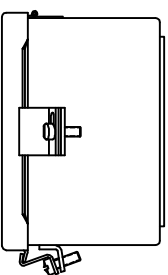

**SECTION A-A**

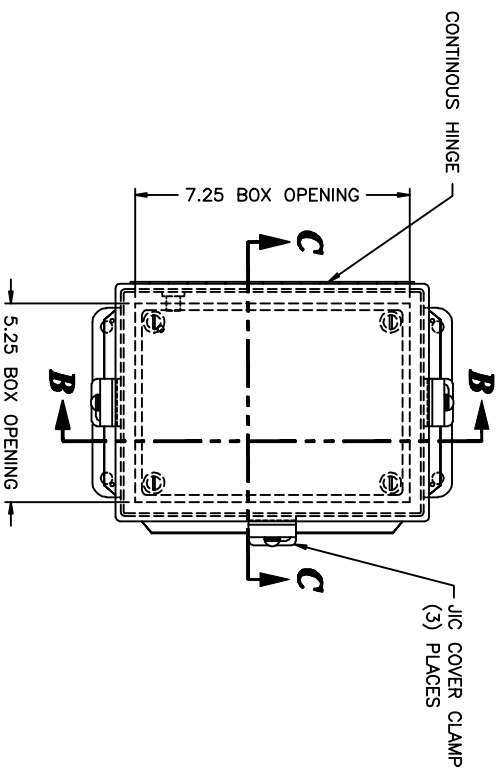

**SECTION B-B**

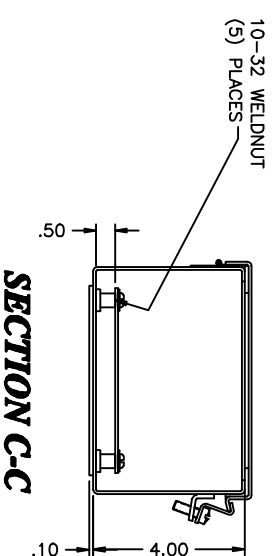
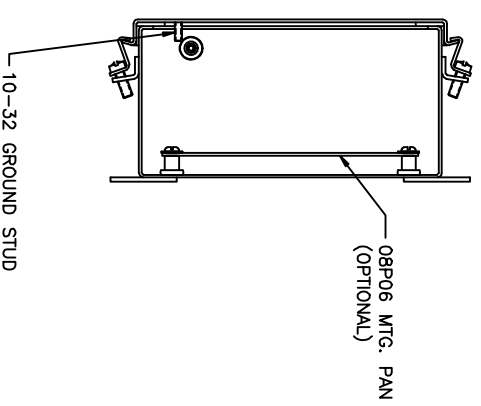

**SECTION C-C**

ENCLOSURE MATERIAL	CATALOG NUMBER	PART NUMBER
SS316L	JN4XHSS6-080604	M10332
SS304	JN4XHSS-080604	M10302

DO NOT SCALE DRAWING		DATE	
DESIGNED BY	DATE	DESIGNED BY	DATE
ISSUED BY	DATE	ISSUED BY	DATE
APPROVED BY	DATE	APPROVED BY	DATE
DATE	TIME	DATE	TIME
080604	10F1	080604	B

ENGINEERING@ADALFT.COM  
ADALFT  
2491330

JN4XHSS-080604 JIC ASSEMBLY  
8/15/03  
1-2.5  
D