

REV	REVISION	BY	ECN	DATE

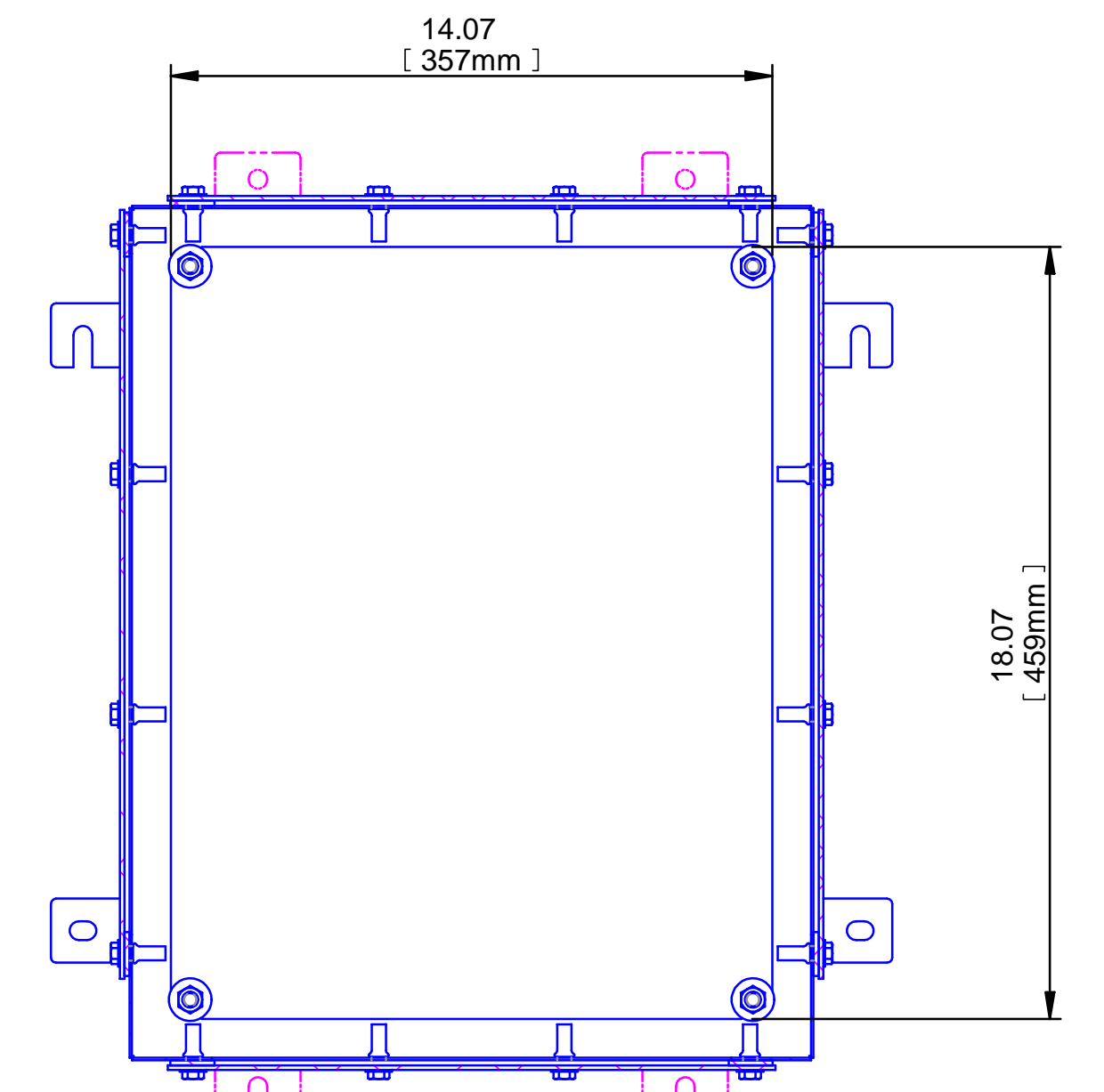

SECTION A-A

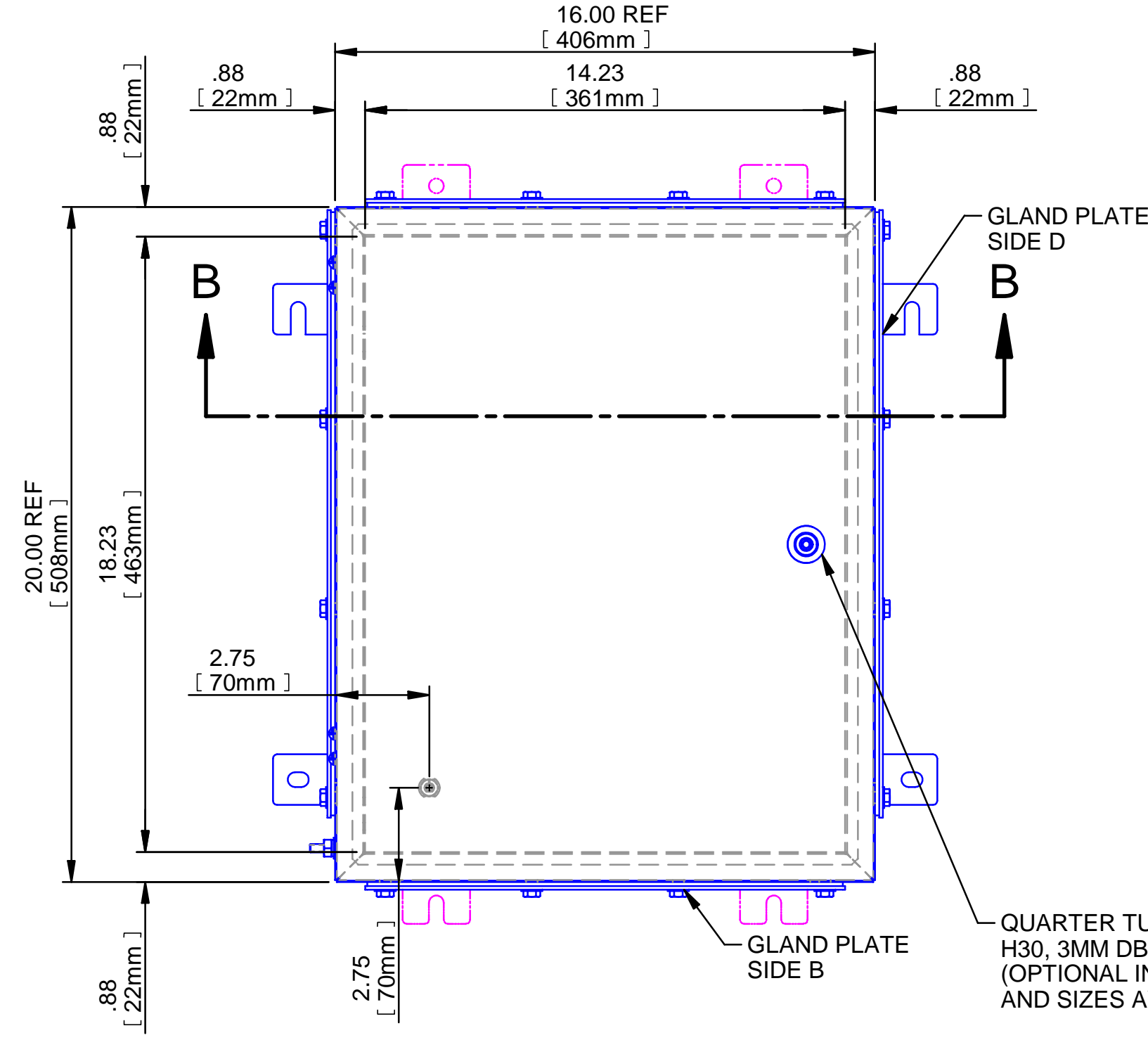
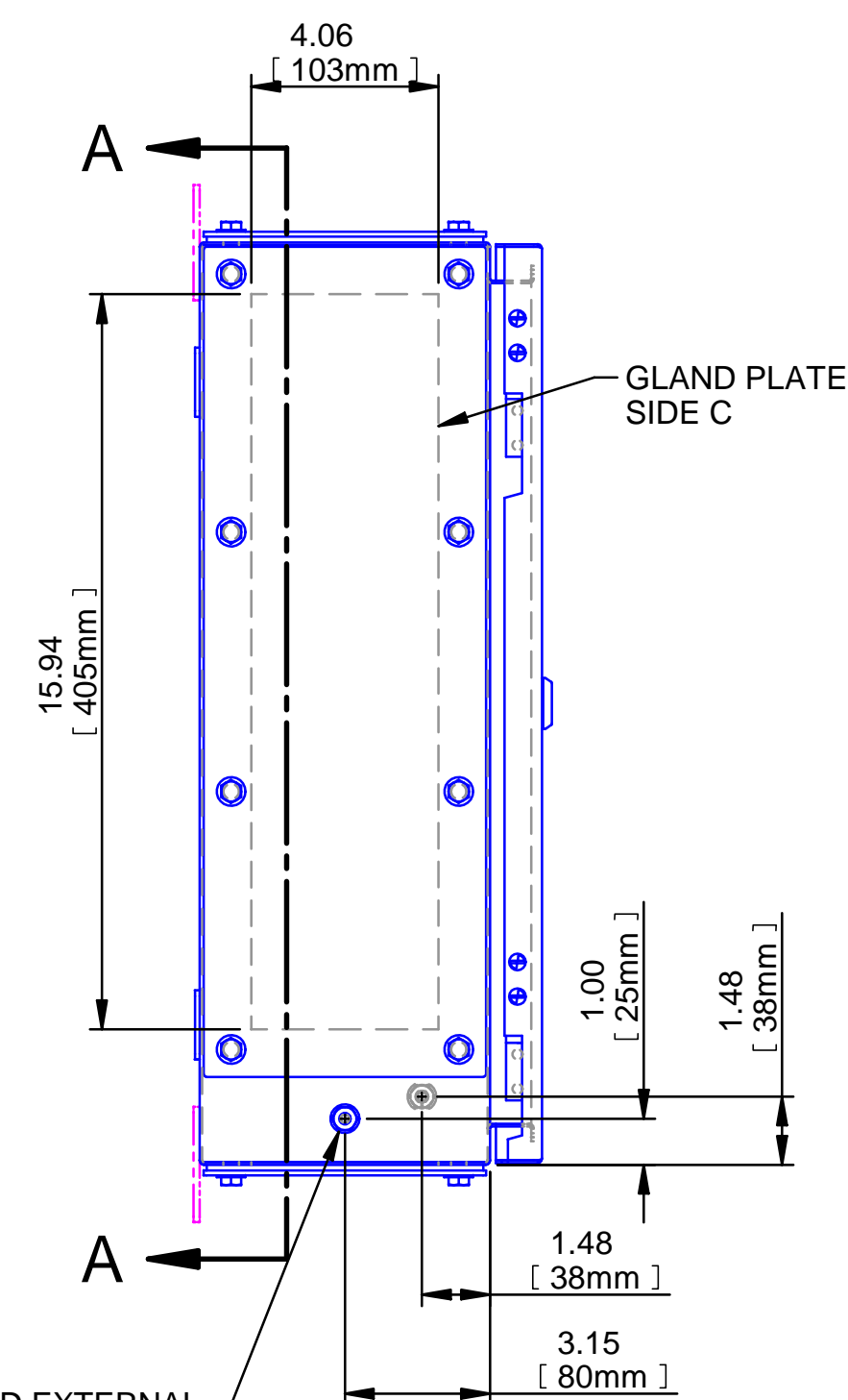
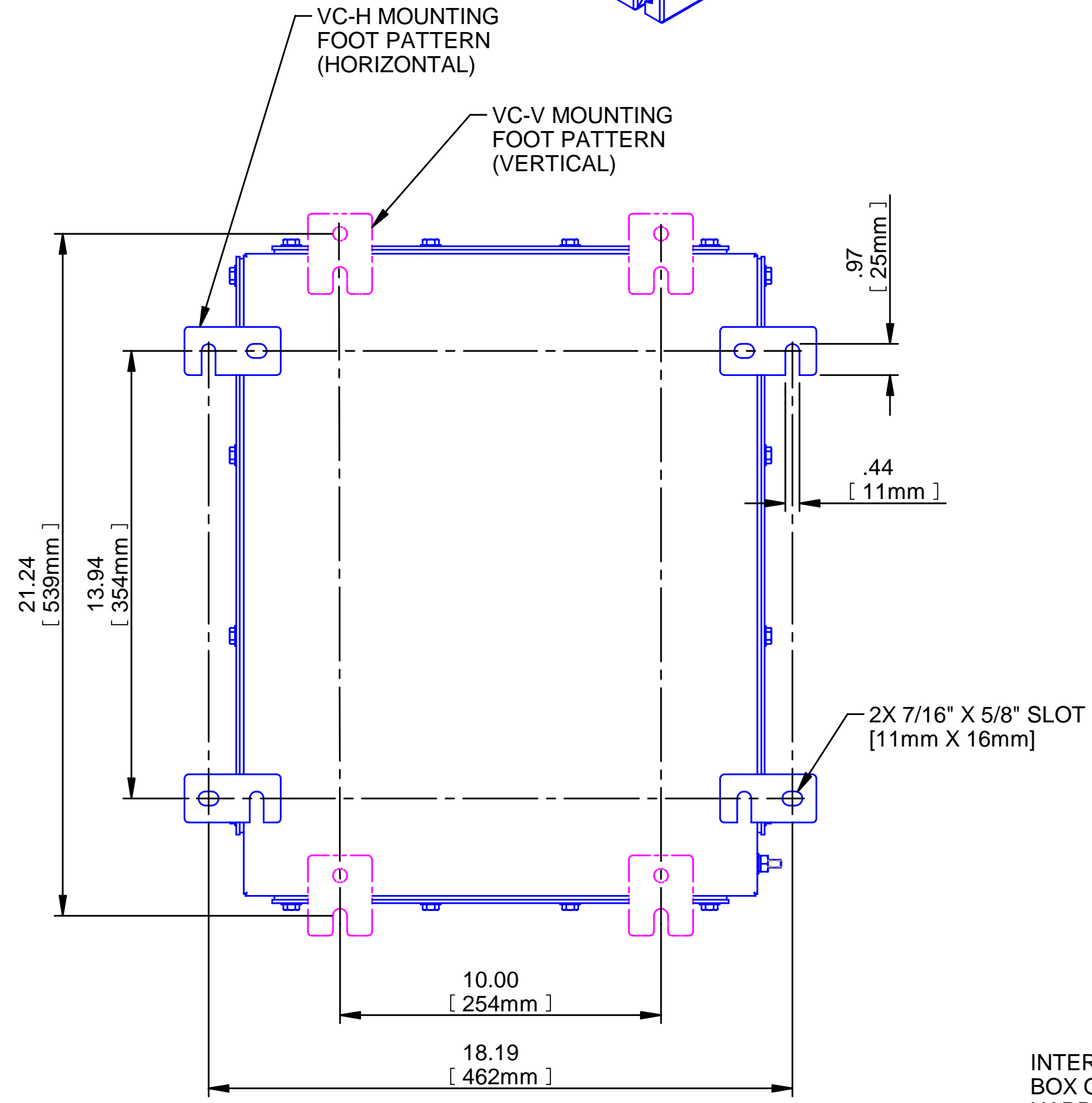
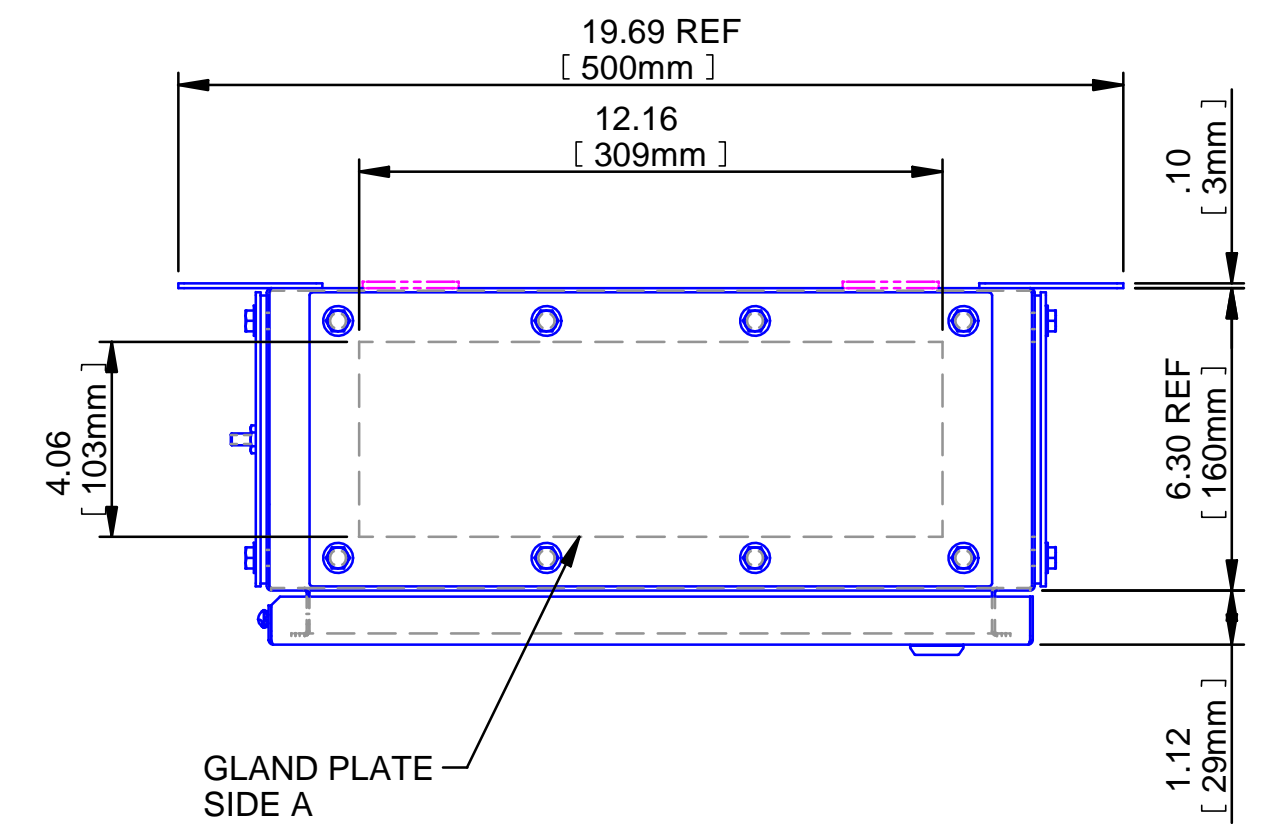
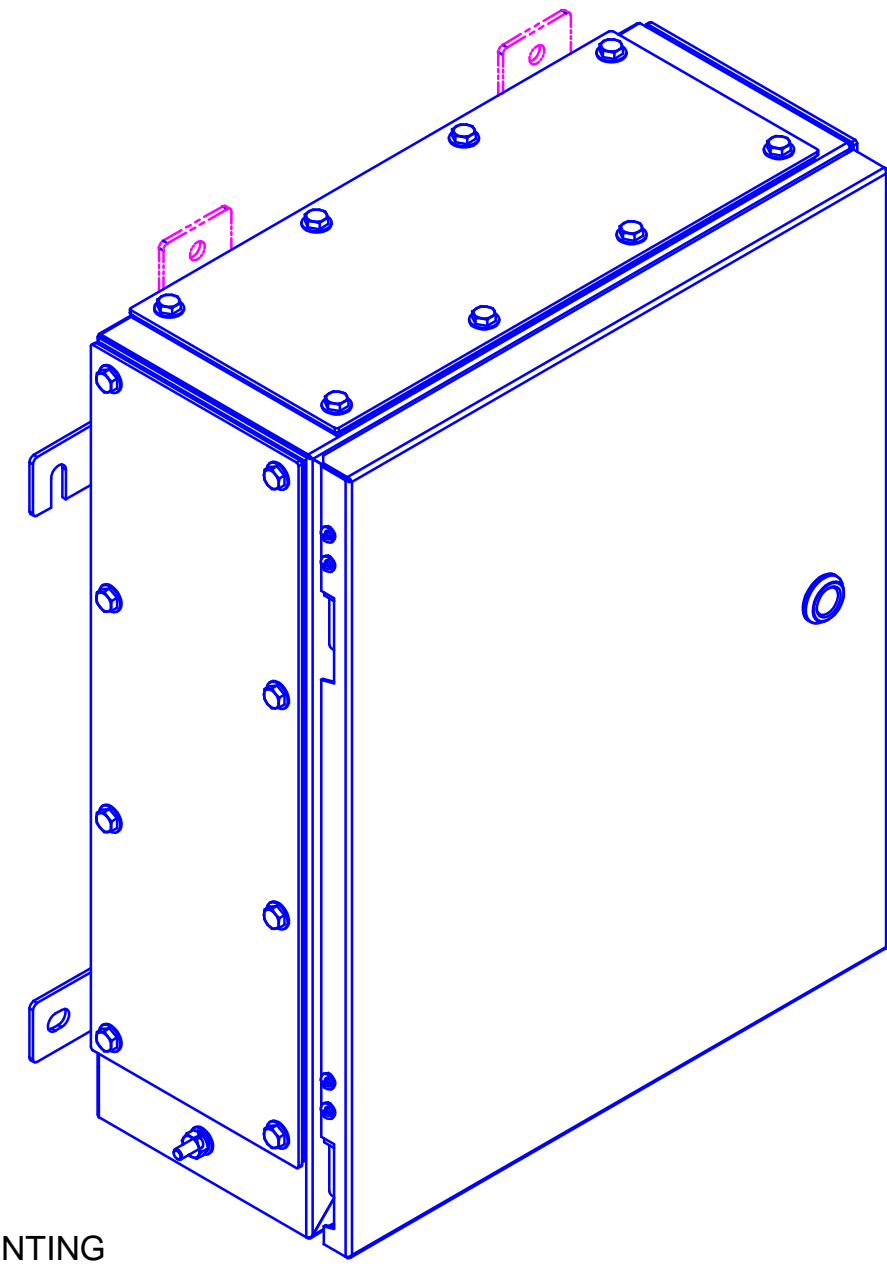
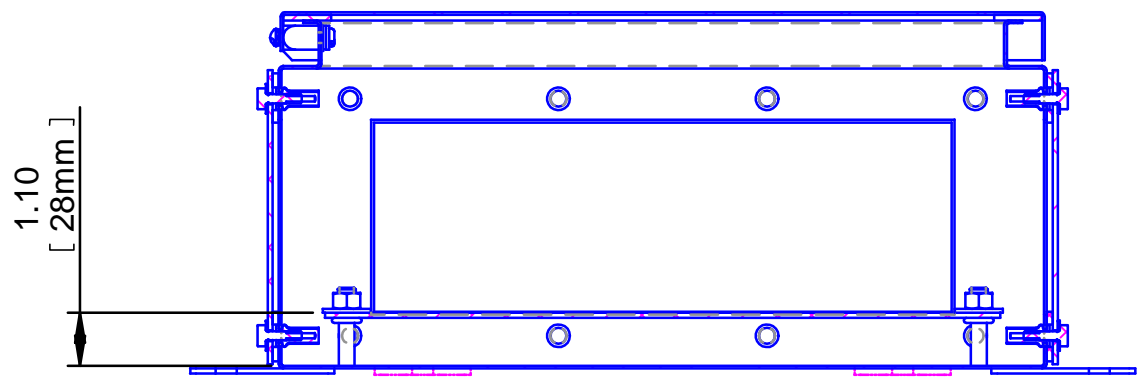

SECTION B-B

INTERNAL AND EXTERNAL BOX GROUND STUD AND HARDWARE PROVIDED

QUARTER TURN, SS316, H30, 3MM DBL BIT (OPTIONAL INSERT TYPES AND SIZES AVAILABLE)

UNCONTROLLED DRAWING (DATA SUBJECT TO CHANGE WITHOUT NOTICE)

DO NOT REVISE THIS DWG. IN AUTOCAD 3D GENERATED IN SOLID EDGE

<p>DO NOT SCALE DRAWING</p> <p>UNLESS OTHERWISE SPECIFIED DIMENSIONS ARE IN INCHES</p> <p>CAST TOLERANCES ON DIMENSIONS NOT OTHERWISE SPECIFIED: <math>\sqrt{.16}</math> STOCK</p> <p>FILLET OR CORNER RADI <math>1/8</math>"</p> <p>DRAFT 1:12</p> <p>FILLET RADI <math>1/16</math>"</p> <p>ANGLES <math>\pm 1^\circ</math></p> <p>MACHINE TOLERANCES ON DIMENSIONS NOT OTHERWISE SPECIFIED: <math>\sqrt{.125}</math> MIN</p> <p>EDGE BREAK .035"-.015" R. or 45°</p> <p>FILLET RADI <math>1/32</math>"</p> <p>ANGLES <math>\pm 0^\circ30'</math></p> <p>GAGING FOR THREADED HOLES NOT OTHERWISE SPECIFIED: MFT E-212.6 NPSM E-241.0</p>		<p><b>ADALET</b></p> <p>A SCOTT FETZER COMPANY</p> <p>Enterprise Systems • Cable Accessories</p> <p>Cleveland, OH 44135</p>		<p>TITLE</p> <p>VC-201606</p> <p>INCREASED SAFETY ENCLOSURE</p> <p>CUSTOMER OUTLINE DRAWING</p>	
<p>NOTICE TO PERSONS RECEIVING THIS DRAWING:</p> <p>ADALET/PLM CLAIMS PROPRIETARY RIGHTS IN THE MATERIAL DISCLOSED HEREIN. THIS DRAWING IS ISSUED IN CONFIDENCE FOR ENGINEERING INFORMATION ONLY AND MAY NOT BE REPRODUCED OR USED TO MANUFACTURE ANYTHING SHOWN HEREON WITHOUT DIRECT WRITTEN PERMISSION FROM ADALET/PLM TO THE USER.</p>		<p>DRAWN BY</p> <p>DMS</p>		<p>DATE</p> <p>12/4/2008</p>	
<p>MATERIAL</p>		<p>ENG APPROVAL</p>		<p>PLOT SCALE</p>	
<p>FINISH</p>		<p>MFG APPROVAL</p>		<p>DWG SIZE</p> <p>D</p>	
<p>CAT NO</p>		<p>DWG NO</p>		<p>SHT</p>	
<p> </p>		<p> </p>		<p>REV</p>	